



SURFACE
FINISH

WHO WE ARE



From an important **group...**

Since more than 40 years, Ecoenerg operates in the electronic field, both civil and industrial. It deals with the production of civil and industrial electrical Systems / Automation / Home automation / VMC equipments / Hydraulic and Heating systems / Civil construction / Sustainable construction / Lighting industry (innovative technologies for energy saving) / Industrial automation / Control panels and cabins / Management and supervision of industrial plants and Building Automation / Software and systems for process control and production management / Techniques and solutions for energy efficiency (existing buildings) / Photovoltaics / Biogas / Biomass cogeneration.



... a great **expertise.**

Established in 2014, ECOLINE is a young company whose engineers and technicians are skilled in the sanding, brushing and finishing of wood surfaces since decades. The joint venture with ECOENERG ensures stability and resources, along with the expertise of our team.

Our technicians are highly specialized in providing technology to all those companies operating in the carpentry field or the aluminium, plastic and other composite materials processing, whether they are small artisans or large industrial groups.

Our technology, protected by more than ten granted patents, makes us leader in our field; we are able to produce Woodworking Machinery using standard technology as well as fully customized projects.

We are a reference all over the world for our customers thanks to our commitment in research.

Using the best materials available on the market, we combine mechanical steadiness and high industrial automation technology that means "reliability and long lasting performances".



PATENTED TECHNOLOGY



LEADER OF TECHNOLOGICAL INNOVATION



SERVICE AND PARTS



QUALITY AND DURATION MADE IN ITALY



ENERGY SAVING



SAFETY AT WORK



LABOR SAVINGS

INFORMATION GENERAL

WIND SAND

Finishing of **excellence**.

C.N.C. FINISHING CENTER, THE WINDSAND SANDING MACHINES ARE USED FOR SANDING AND DENIBBING OF WINDOW SASHES AND FRAMES, DOORS AND PANELS GENERALLY. THESE MACHINE LINE IS THE GUARANTY TO OBTAIN THE BEST SURFACE QUALITY THROUGH HIGH PERFORMANCE EQUIPMENT. ALL SIDES ARE SANDED THROUGH A DEDICATED AGGREGATE THANKS TO OUR PATENTED TECHNOLOGY DEVELOPED THROUGH DECENCIES OF EXPERIENCE.

- Steel structure ensures stability and strength.
- Ground working tables maintain parallelism with sanding disks.
- All adjustments of the operating units are on ball bearing linear guides to ensure long life, accuracy and high strength.
- Powered feed belts for the work-piece movement, feed speed driven by inverter.
- Pressure rollers all along the working process to ensure work-piece's stability.
- Pressure rollers coated with vulcanized rubber and provided with spring-loaded suspension.
- All working units provided with dust extraction.
- Cabin closes on six sides.
- Side doors provided with safety system, machine stops in case of door opening. Doors have windows to allow the control of the work-piece.
- Steel side reference guide of right hand machine entrance (zero reference).



WORKING PROCEDURE

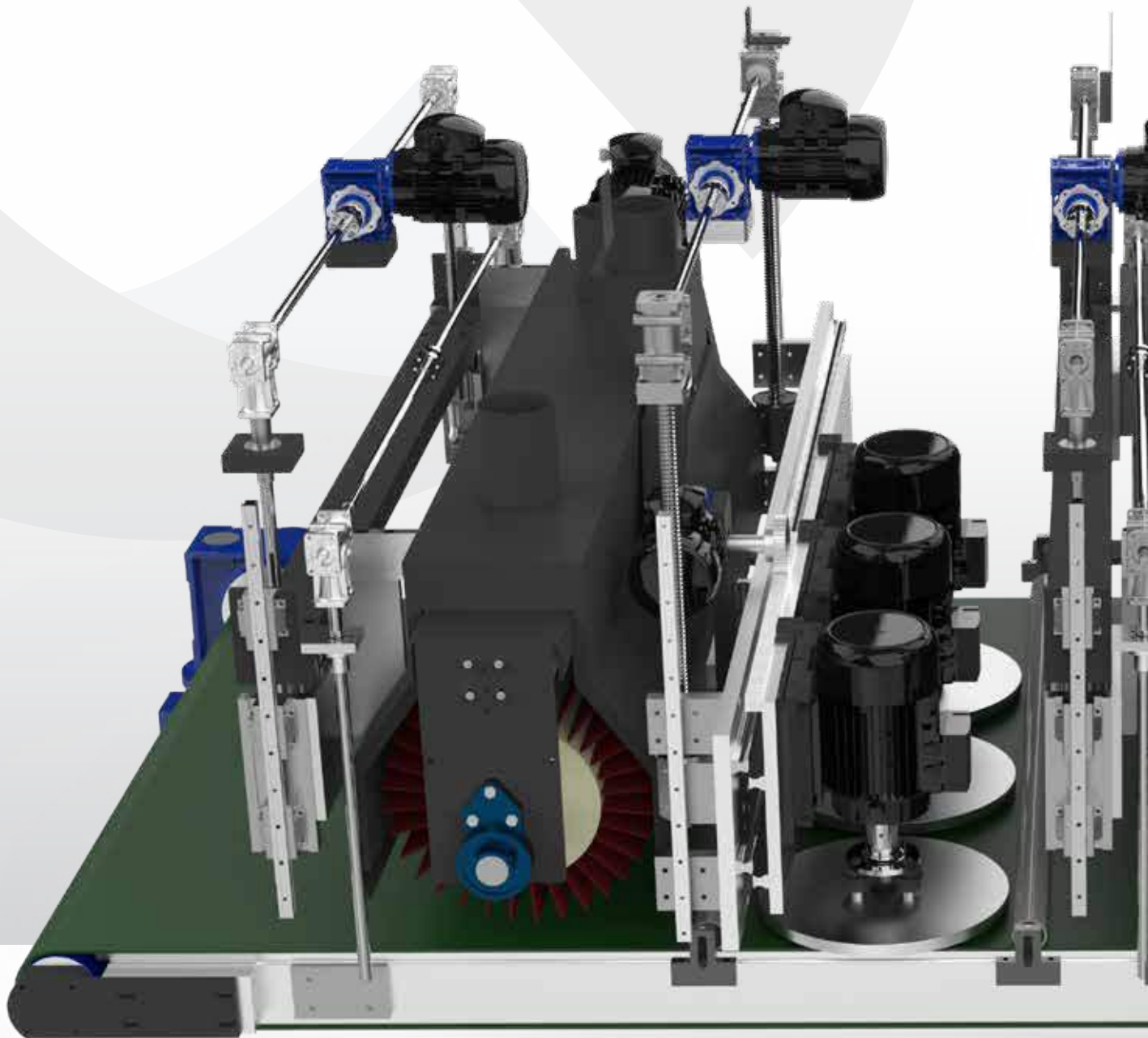

The working cycle is very easy thanks to the high level of automation.

WORKING CYCLE

- Choice of pre-set working program
- Working and pressure units adjust automatically according to the selected program and the parameters entered.
- The working cycle starts by setting work speed, the pressure of the units and rotating speed according to the selected program.

WIND SAND

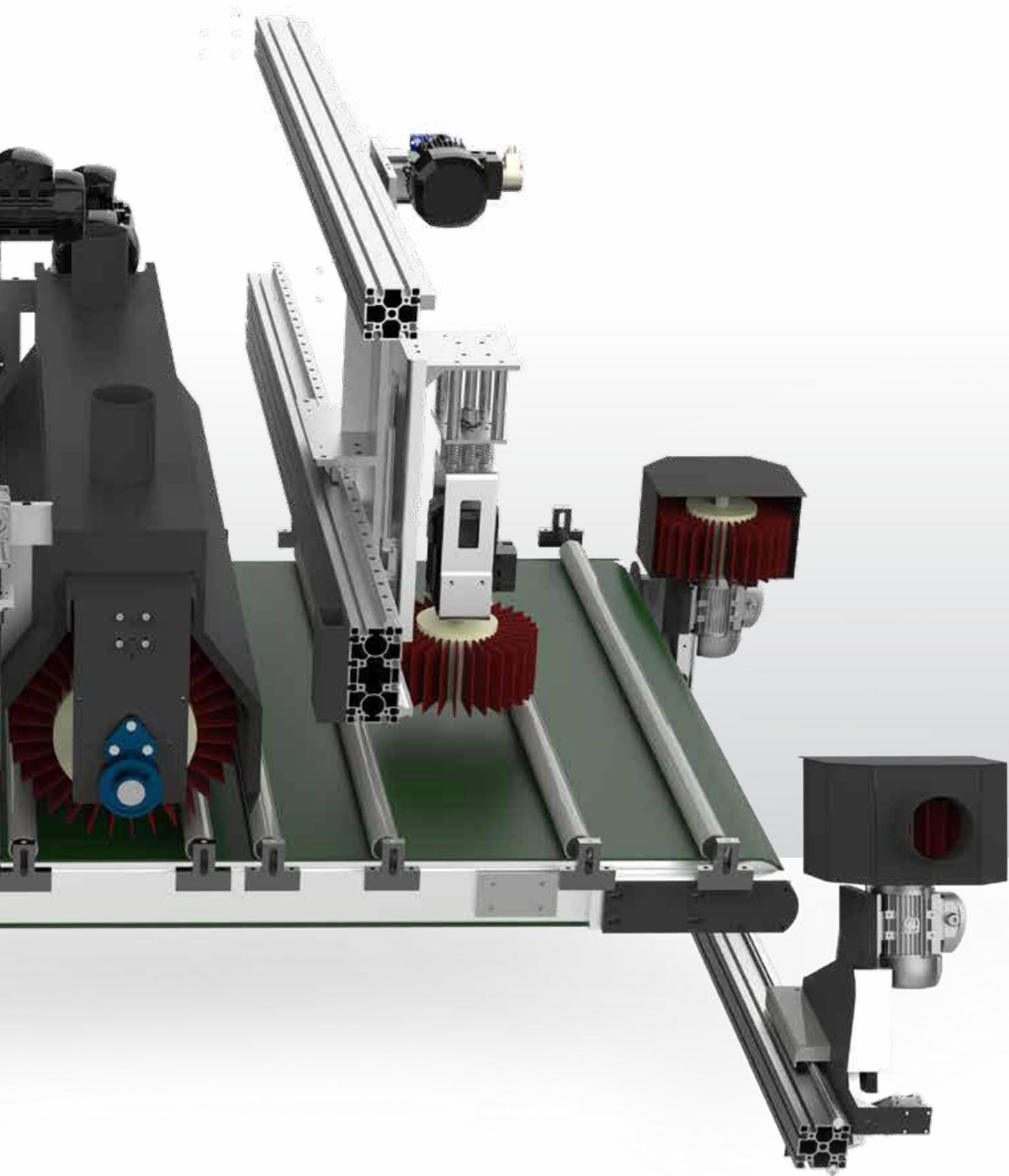

MACHINE CONFIGURATION

- All working units are driven by Inverter
- All brushes and sanding disks are provided with individually replaceable abrasive strips or sandpaper
- Thanks to the innovative Ecoline operating system, all working units ensure the maintenance of the work-piece geometry

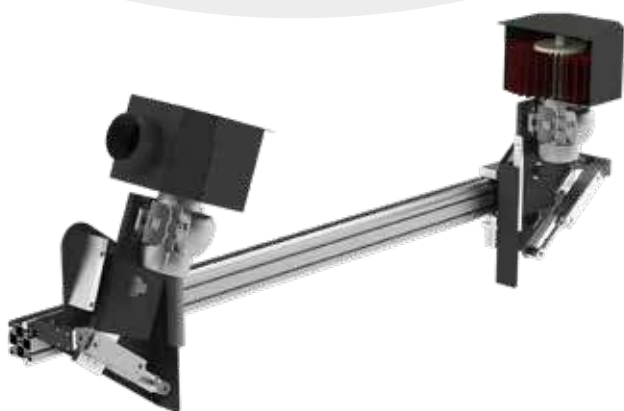

VERTICAL BRUSHES

1

Nr.2 350 mm dia. vertical brushes, 0,55 kw motor each, variable rotating speed driven by inverter. Variable inclination 0°-35°. Horizontal stroke adjustment on linear guides.



CENTRAL BRUSH

3

350 mm dia. vertical brush for sanding work-piece head and inside of the window. kW 0,55 electronically controlled variable rotating speed by inverter.

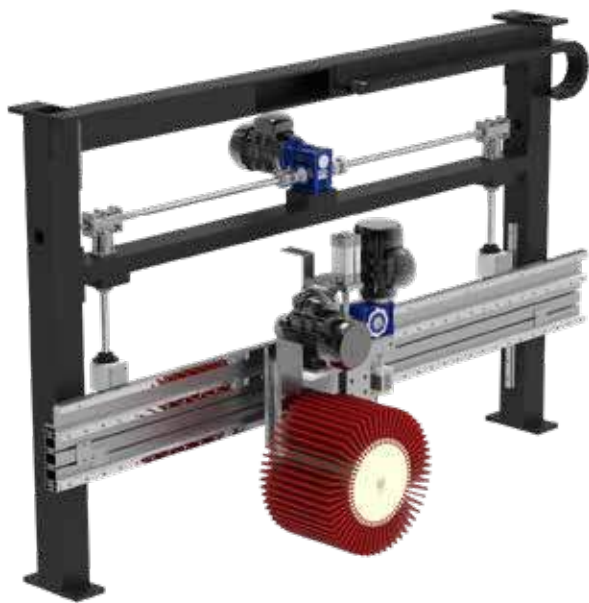

TRANSVERSAL BRUSHES

4

Nr 1 transversal brushes 320 mm dia. Kw 1,5.
Electronically controlled variable rotating speed by inverter.
Vertical stroke 100 mm on linear guides and positioning control by reader.
Easier horizontal extraction for abrasive strips change.



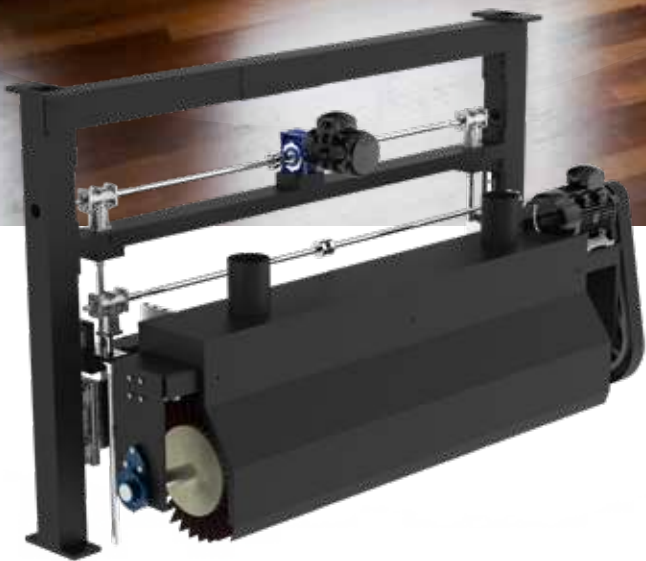

HORIZONTAL BRUSH _____

Nr 1 horizontal brush Ø 420 Abrasive brush consisting of a cylinder with interchangeable strips.

5



SANDING DISKS (CUPS) _____

Nr. 3 420 mm dia. sanding disks driven by 1.5 kw motor each, electronically controlled variable rotating speed by inverter. Easier horizontal extraction for abrasive change.

6 (8)

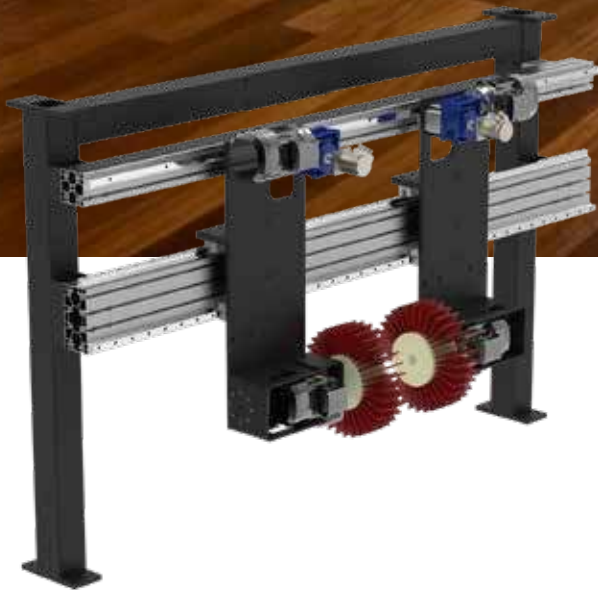

DOORS UNIT

7

Unit consisting of 2 independent brushes 350 mm dia. Kw 0,75 each. Horizontal movement on linear guides and 2 vertical position 20-40mm. Electronically controlled variable rotating speed by inverter.



3D UNIT

9

Unit composed by 5 cylindrical brushes \varnothing 320 mm with vertical and horizontal independent rotation. particularly indicated for milled surfaces or internal parts of the work-piece.

ECOLINE SYSTEM

ADVANTAGES

- Labor cost cutting and healthy job.
- Excellent finishing results thanks to the fibre cut cross system.
- The high accuracy of sanding disk adjustment ensures excellent results on rough, impregnated, or lacquered surfaces.
- Fully automatized working cycle with fast positioning when the work-piece need to be change.
- Geometry of the workpiece's edges ensured by the electronic adjustment of working units.
- Steady worktable height allows the installation of the machine on working lines.
- High degree of feed and rotating speed modulation.
- Working units provided with an additional adjusting system to change the work pressure and compensate abrasive wearing.
- Low maintenance cost due to the possibility of replacing single abrasive strips.
- The fully closed cabin ensures almost zero dust emission and a complete safety for the operator.
- Easy maintenance and adjustments.

ACCESSORIES

- Out feeding table
- Orizontal brush motor power kw 7,5
- Cup brash
- Extra set abrasive paper
- Tynex brush brushes
- Still brushes

HMI

Full PLC control.

Choice of programs and settings through colour touch screen.

Wide memory capability to save pre-set programs.

External USB support to export programs.

Large and understandable icons for easy and friendly use.

Automatic control of abrasive workload and replacement.

Remote after-sale service. (need of Internet connection).



		WINDSAND 2	WINDSAND 3	WINDSAND 4	WINDSAND 5
Codes / GROUPS		EC 56 -000 EC 66 -000	AL 156 -000	AL 135 - 600 AL 168 - 500	AL 135 - 460 AL 157 - 460
Dimensions (length x width x height)	mm	2900x2300x2200	2900x2300x2300	2900x2300x2300	3900x2300x2300
Working table height	mm	875	875	875	875
Weight	kg	4000	4500	4000	4500
Operating voltage		400 V	400 V	400 V	400 V
Electric current		63 A	63 A	63 A	63 A
Electric power	Kw	11	11	11	11
Frequency	Hz	50	50	50	50
Electrical cabinet protection		IP 55	IP 55	IP 55	IP 55
Air connection	bar	6	6	6	6
Dust extraction	mm	Nr 4 x Ø 120	Nr 5 x Ø 120	Nr 5 x Ø 120	Nr 6 x Ø 120
Workpiece dimension					
Shortest piece	mm	550	550	550	550
Max. width	mm	1550	1550	1550	1550
Min. thickness	mm	10	10	10	10
Max. thickness	mm	120	120	120	120
Equipment					
Certification		CE	CE	CE	CE
HMI		Touch screen 11 inch	Touch screen 11 inch	Touch screen 11 inch	Touch screen 11 inch

- 1** Vertical brushes
- 3** Central Brush
- 4** Transversal brushes

- 5** Horizontal brush
- 6** Sanding disks
- 7** Doors unit

- 8** Cups
- 9** 3D Unit



Via Ceratelli, 2 - 46043
Castiglione d. Stiviere (MN) - Italy
Tel. +39 0376. 1514601 / 609

info@ecoline.info
www.ecoline.info