

Robot Integration in a small space.

Manufacturing cell for automatic material handling
FEEDBOT D-300 and DRILLTEQ V-500





Robot Integration – FEEDBOT D-300 with vertical CNC processing center DRILLTEQ V-500

The manufacturing cell with robot for automatic material handling

Availability of nearly 100 %, high repeatability and pinpoint workpiece handling – robots are reliable partners and automatically increase the efficiency of production. The reliable workpiece supply of the robot system turns every CNC machine into a high-performance center and thus an optimum production cell in wood and furniture production.

YOUR SOLUTION

MORE ON HOMAG.COM



CONTENT

- 04 Advantages of robot part handling
- 06 Models FEEDBOT D-300 Advanced and Basic
- 07 Process description
- 08 Machine monitoring with MachineBoard
- 09 Control and operation
- 10 Stacking patterns, technical parameters
- 11 Technical data
- 12 tapio
- 14 Life Cycle Service

Advantages of automatic material handling with robot support

FEEDBOT D-300, in Basic- or Advanced-Version, on DRILLTEQ V-500 vertical CNC processing center.
Safe, precise, automatic handling of workpieces for more efficient production.



A CNC processing center with robot support forms one of the smallest possible cells of the furniture production. In this combination, the FEEDBOT increases your overall productivity. It does not have to take a break, can work around the clock on the shop floor and ensures consistently high quality. Small and medium-sized companies save a lot of

time by using the FEEDBOT D-300 and reduce the workload for their staff. The resulting flexible manpower organization allows your workforce to be used more for value-added activities and production processes. The result is added value for your plant in terms of quality, availability and performance.



ADVANTAGES OF ROBOT INTEGRATION AT A GLANCE:

- **High availability –**
Machine running time can be extended to almost 100 %
- **Long lifetime –**
no need to search for new workers
- **Highly flexible production –**
No training of new processes necessary
- **Low maintenance operation –**
24/7 availability (no vacation, sickness, breaks)
- **High cleanliness and low noise**
- **Ergonomics friendly –**
Manual parts handling almost completely eliminated
- **Consistently high quality –**
No reduction / change due to change of workers
- **Everything from a single source –**
Liability and safety, CE, one contact, HOMAG service
- **Processing on both sides –**
Possible due to return conveyor at the drilling machine

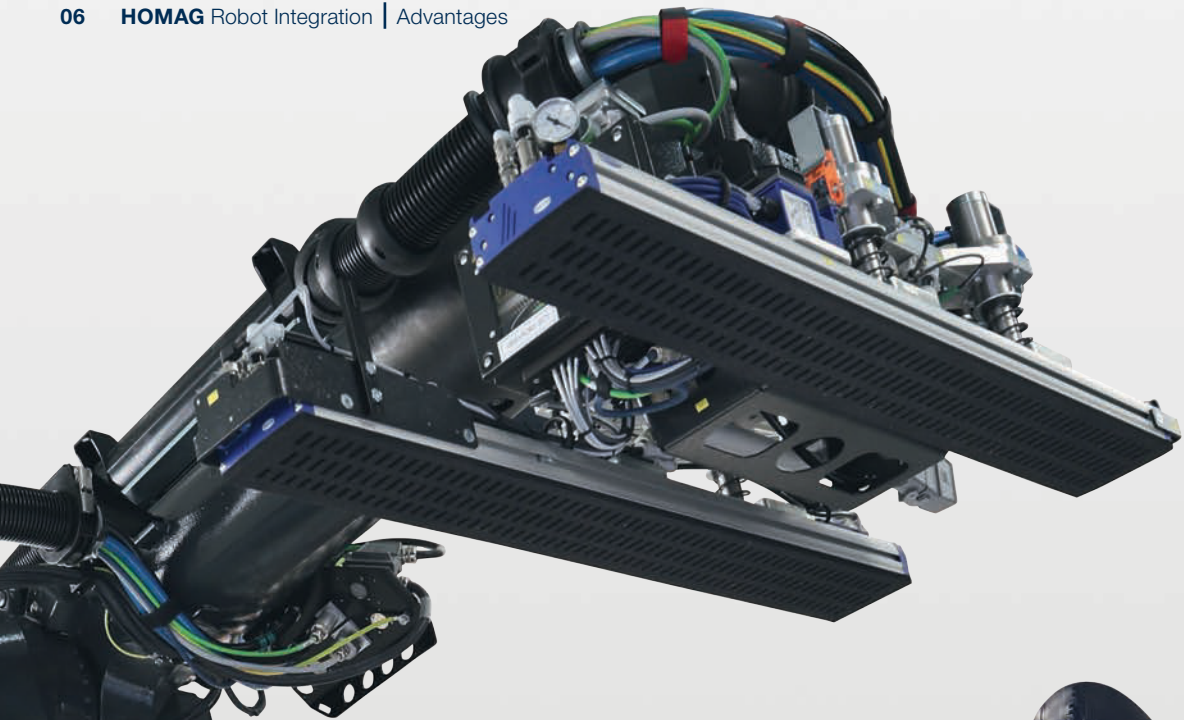

FEEDBOT D-300 ADVANCED

- Sensitive contact with the CNC pins - thanks to the floating crosshead - ensures gentle operation
- Large workpiece variance
- Automatic setup of the cell (CNC and robot) as well as visualization in woodFlex
- Plausibility check: comparison of the data from the control to the actual part



FEEDBOT D-300 BASIC

- Simple suction beam without compensation joint
- Gripper optionally with BARCODE READER
- Operation via the Smartpad – no integration into the cell control of the DRILLTEQ V-500



1b

Process Overview

Your production becomes more flexible with the support of the FEEDBOT D-300 and the firmly defined processes more flexible and more agile. Markings on workpieces and material

increase and for your employees fatiguing, uncomfortable tasks are carried out by the robot. Even small batch sizes can be produced without any problems.

Standard operation / normal mode

- 1 Raw parts are provided as stacks on pallets**
Feedbot Advanced: The robot determines the position of the workpiece to be loaded by means of sensors.
Feedbot Basic & Advanced: The workpiece is separated from the stack by means of tilting incl. subsequent part validation.
- 1b Feedbot Basic:** Alignment of the workpiece to the zero point via the inclined plane. This place can also be used as a buffer space to ensure faster parts feeding, as this is done in the machining time of the machine.
- 2 The unmachined part will be inserted by the robot into the CNC machine**
Feedbot Basic: Subsequently positioning the workpiece against the stop pin of the drilling machine.
Feedbot Advanced: The workpiece is held by means of a compensating joint on the the robot gripper against the stop pin of the CNC machine. Subsequently the CNC machining starts.

- 3 Removal of the finished parts**
- 4 Manufactured parts are placed on the target stack.**
 The next workpiece will be measured and inserted into the machine.

Extension workflow through return conveyer

- Option A**
 Workpieces from the return conveyer **5** can be fed again to the CNC **2** (2nd run, the part was turned over for machining on both sides).
 After the second run through the CNC, parts are output to the return conveyer and finally placed on the target stack **4**.
- Option B**
 Parts are transferred to the return conveyer **5** after the first pass through the CNC and then placed on the target stack **4**.

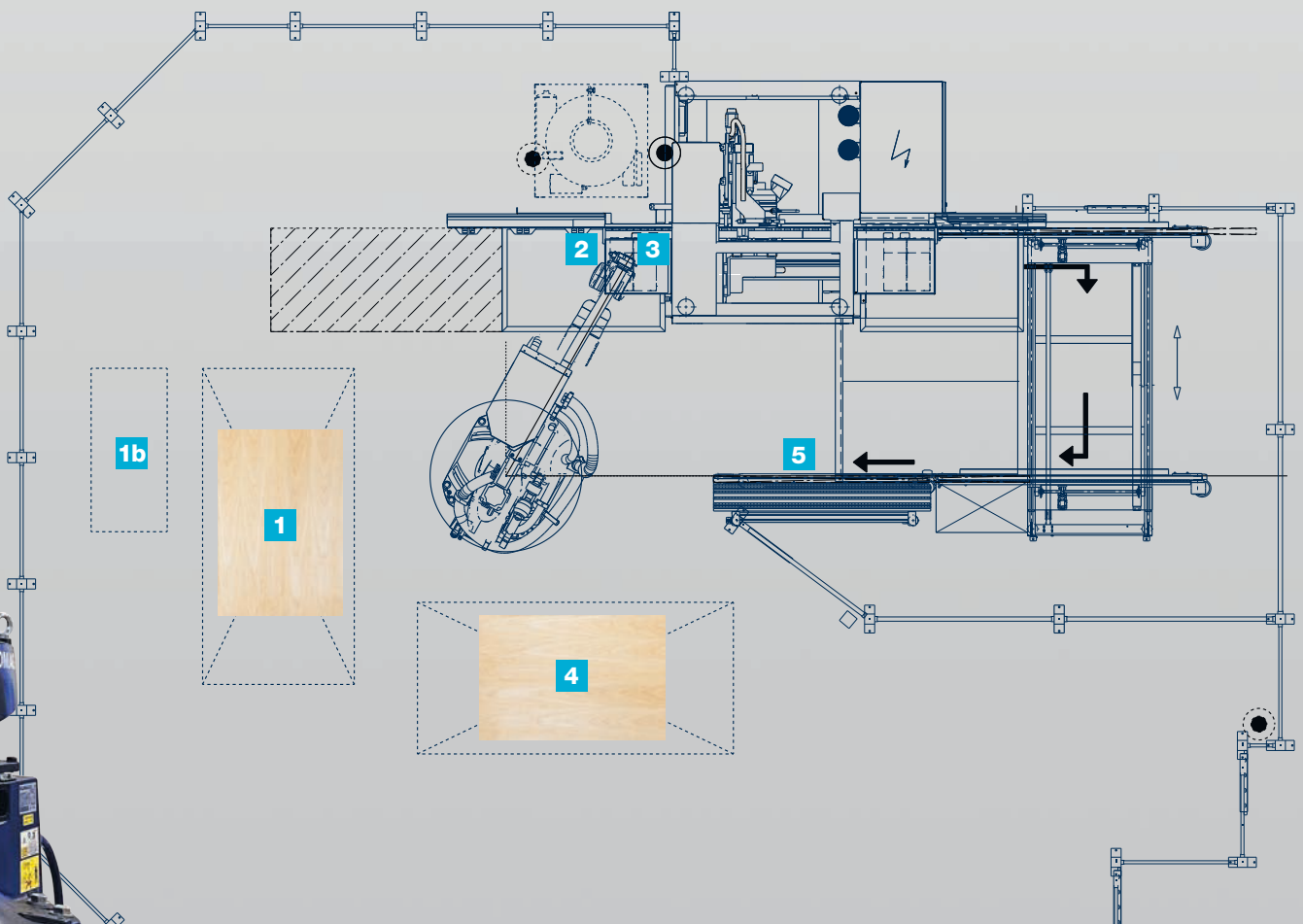

Machine monitoring with MachineBoard

With this app, you can always keep an eye on the FEEDBOT D-300 and DRILLTEQ V-500, even when you're not on site. Simply see the status and condition of the machines at a glance.



BENEFITS:

- Easy overview of all machines, location-independent
- Push notifications for alarms
- Always on time at the machine
- More flexibility in daily work
- More time for daily work

FUNCTIONS:

- Push notifications
- Machine data and status in real time
- Lists of errors, warnings, servicing and actions
- Display of remaining production time

WoodFlex visualization

This control system provides networking, has a modular design and is open for future requirements or expansions. woodFlex creates safety, optimizes processes and increases efficiency.

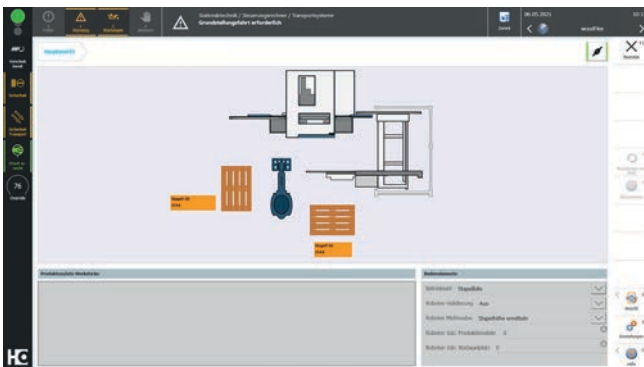

woodFlex

- Visualizes the cell in real time
- Connects the two machines into one cell
- Automatic setup of both machines

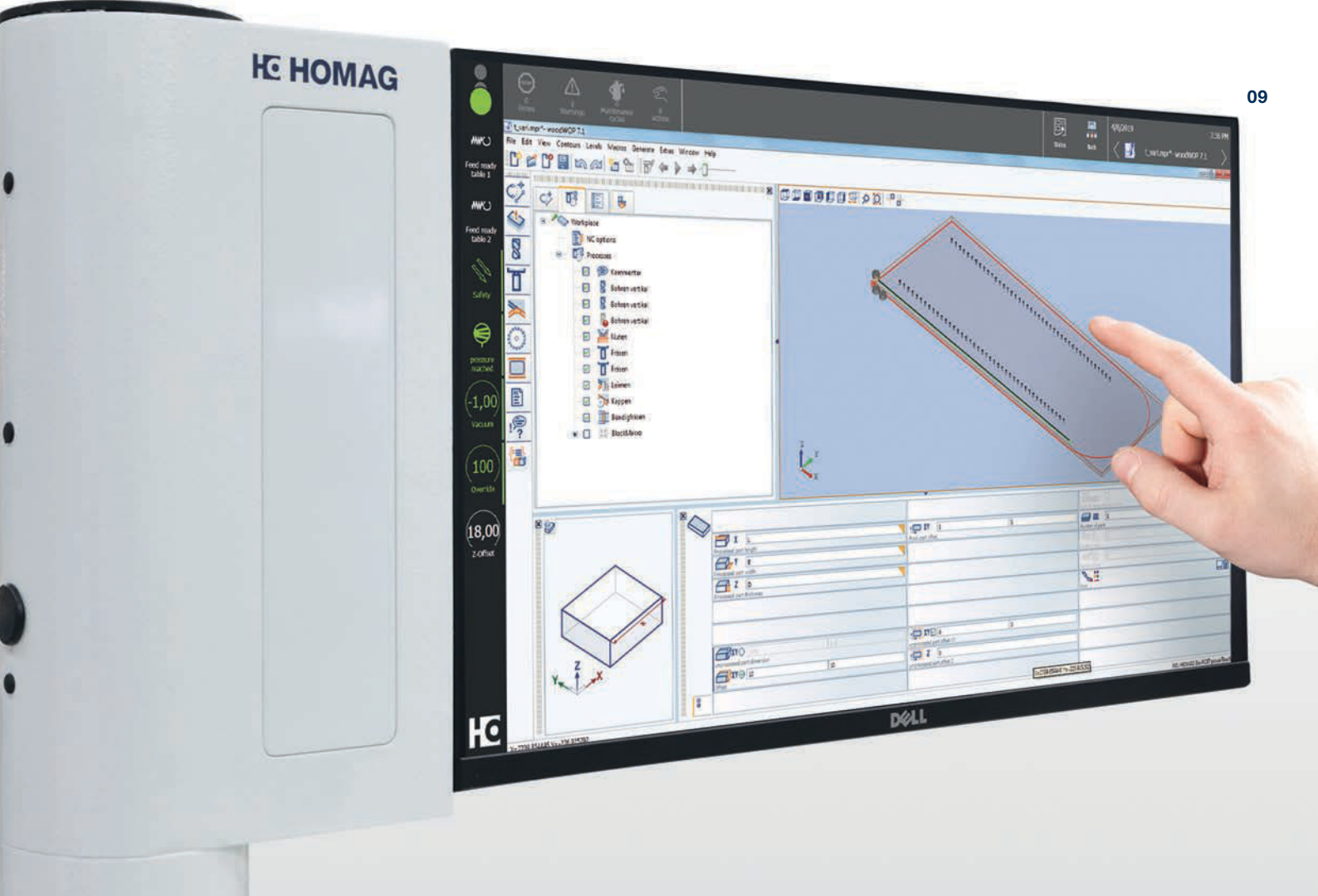

Control and operation

Operation

Via the HOMAG powerControl with powerTouch2.

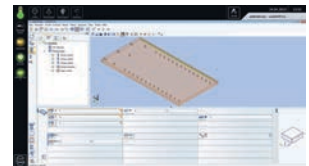

Control

Via stacking lists or via a barcode (optional). For the application the cell control woodFlex is used. This enables automatic setup of both machines.



2 operating modes

Automatic (robot loads and unloads CNC).

Manual (robot deactivated, operator can run CNC autonomously).



Barcode reader

Workpieces can be identified via the label in batch size 1 operation. The barcode is applied lengthwise/crosswise centrally on the top of the blank.



Stacking patterns and technical parameters



Stacking pattern 11: for batch size 1 and series parts

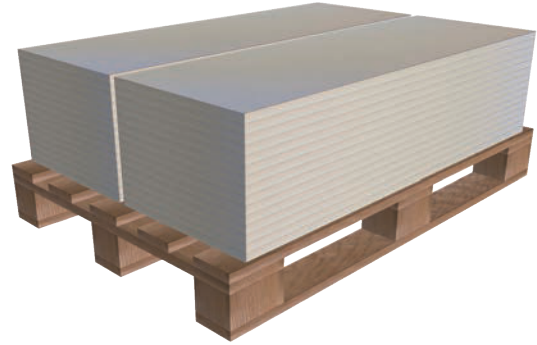

Stacking pattern 21: for series parts

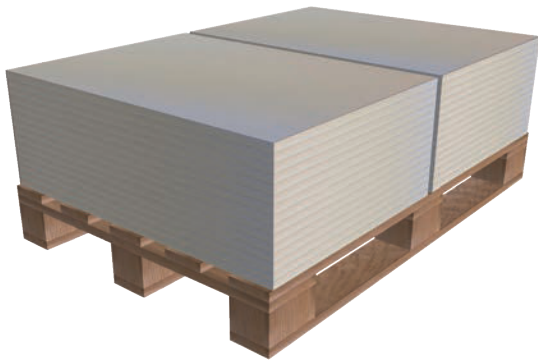

Stacking pattern 112: for series parts

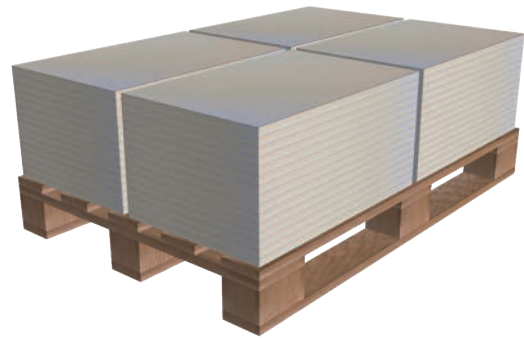

Stacking pattern 22: for series parts

These stacking patterns are the standard stacking patterns for the cell.

TECHNICAL PARAMETERS

Carrier material:	<ul style="list-style-type: none"> - Chipboard - MDF - HDF - plywood, solid wood
Surfaces:	<ul style="list-style-type: none"> - Melamine - Raw (carrier material does not soak through) - Veneer - Laminate - No overlap (optional)
Special workpieces:	Highly structured or absorbent materials and workpieces with high adhesion must be requested separately in the engineering department.
Max. Stacking height:	1,500 mm incl. base frame



Technical data

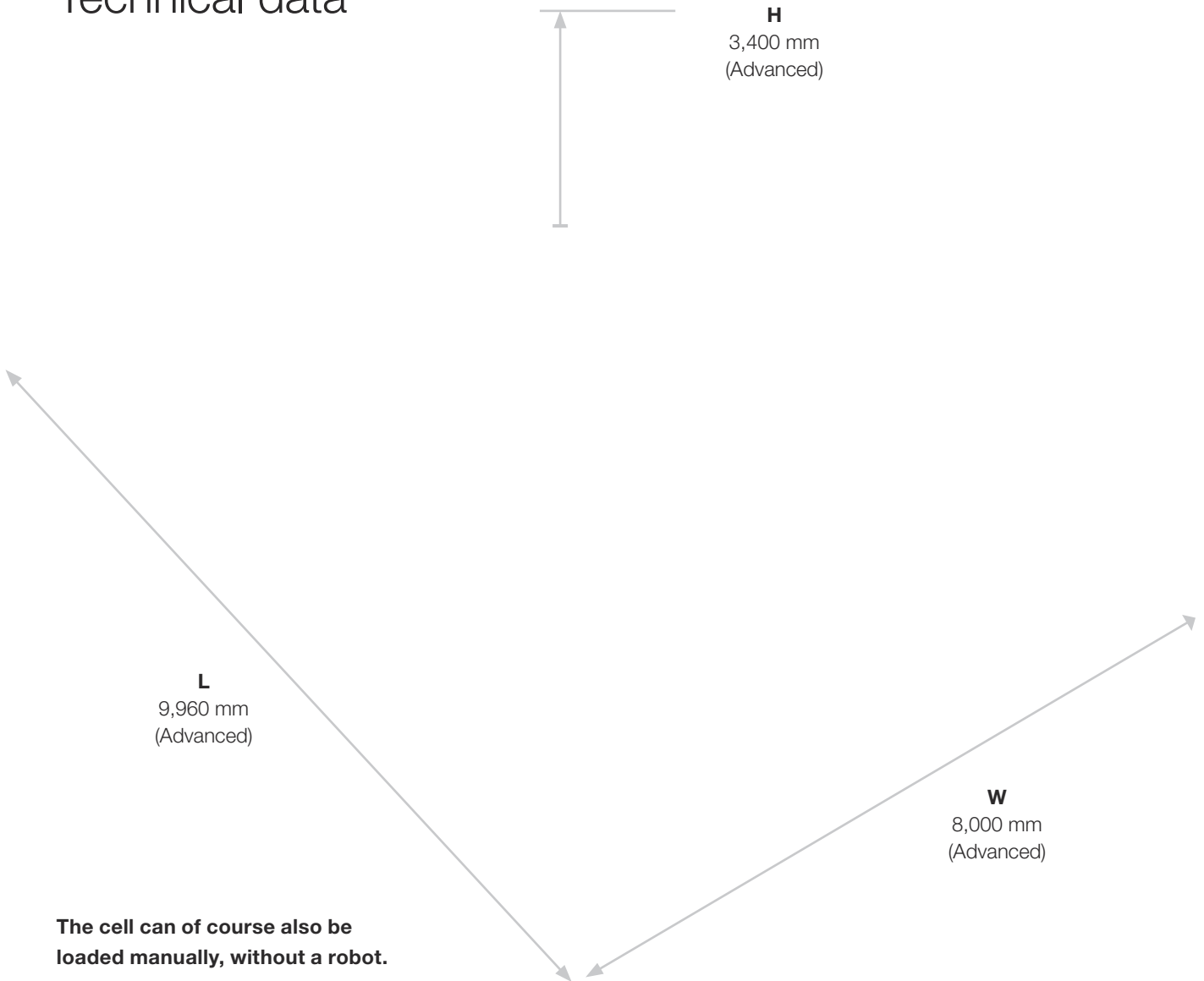

TECHNICAL DATA

			DRILLTEQ V-500 with FEEDBOT D-300	DRILLTEQ V-500 with return conveyor (short version) and FEEDBOT D-300	DRILLTEQ V-500 with return conveyor (long version) and FEEDBOT D-300
(B) = FEEDBOT D-300 BASIC (A) = FEEDBOT D-300 ADVANCED					
Workpiece dimensions max. with manual feeding	L x W x H	mm	3.050 x 1.250 x 80	2.300 x 1.250 x 80	3.050 x 1.250 x 80
Workpiece dimensions min. with manual feeding	L x W x H	mm	200 x 50 x 8	350 x 60 x 8	350 x 60 x 8
Workpiece dimensions max. with feeding via FEEDBOT D-300	L x W x H	mm	1.600 x 900 x 60 (B) 2.500/3.050 x 1.200 x 60 (A)		
Workpiece dimensions min. with feeding via FEEDBOT D-300	L x W x H	mm	350 x 200 x 10 (B) 350 x 120 x 10 (A)		
Workpiece weight max.		kg	30 (B) / 60 (A)		
Installation dimensions	L x W x H	mm	10.020 x 8.000 x 3.400	9.960 x 6.000 x 3.400 (B) 9.960 x 8.000 x 3.400 (A)	7.960 x 6.000 x 3.400 (B) 10.520 x 8.000 x 3.400 (A)

Easy to get. And easy to use.

tapio is the open wood industry ecosystem

This means that everyone involved in the wood industry can participate.
Because together with our business partners, we develop digital solutions for everyone.



Just have a try:

Free use of the MachineBoard app! Just register under tapio and “connect” the machine www.tapio.one. The complimentary usage is limited in time.

Apps that make working life easier.

tapio

Partner

DataSave

- Protects machine and configuration expertise
- Faster service for machine breakdowns
- Saves time when restarting production
- Saves on maintenance costs
- Automatic backups of several machines

ServiceBoard

- Create service cases quickly and easily and send them to the correct service partner
- Live video diagnostics to solve service cases with image support
- Video reduces the language and distance barriers
- Also works without a machine connection to tapio (and is therefore ideal for older machines)

MachineBoard

- Push notifications
- Machine data and status can be viewed from anywhere in real time
- Lists of errors, warnings, maintenance tasks and actions
- Displays the remaining time until the next intervention by the machine operator



Free demo for all tapio apps, no registration required. Simply download and test.

Currently available in the EU and Switzerland.

(Due to the fast pace of the IT-landscape, the compatibility to the tapio platform is warranted for five years.)

VALYOU

Our Mission, Your Performance.

HC LIFE CYCLE SERVICES

Improved performance, more efficient processes, faster help, assurance of availability and smarter working

TEAM & COVERAGE

Largest global service network in the industry with over 1,350 personnel.

INSTALLATION & COMMISSIONING

For a smooth start, we only let proven experts manage your setup.

OPERATION & CONTROL

After teaching your personnel the intuitive control system, our clever apps help to make the operator's life much easier.

MAINTENANCE & SERVICING

To keep things running, we're happy to take a preventative approach. You decide how often and how intensively you want the support to be. As we all know, prevention is better than the cure.

eSHOP & ONLINE ADVANTAGE

A few clicks and it's fixed. Receive exclusive advantages by ordering spare parts online, depending on market availability.
shop.homag.com

HOTLINE & READINESS

When there's an emergency, we're here. Direct by phone, digitally via app or video, or with on-site support. We are close to you with over 90 regional service organizations worldwide. With more than 35,000 spare parts immediately available, we can deliver 85% of your orders fast.

TRAINING & EDUCATION

With classroom, live online or eLearning training, we offer flexible options to help you get knowledge. We conduct over 4,000 customer training courses every year, and we even have our own training centers in 19 countries

MODERNIZATION & IMPROVEMENT

Our modernization program is tailored to your machines and processes. We can evaluate your data and situation and advise you on the next step.

ANALYSIS & SUSTAINABILITY

On request, we analyze all your processes with proven tools and procedures (LeanSixSigma). We have a large, certified team of experts for this purpose.

FINANCING & CONSULTING

We offer you tailor-made financing concepts worldwide. With more than 60 years of experience and a close partner network of prominent banks and insurance companies to help us to find the right solution for you, we're always transparent and reliable in processing.



Fast support:

94% resolution rate
via our hotline

Close to you:

1,350 service experts worldwide

We get things moving:

Over 1,000 worldwide spare parts
shipments each day

No one else has that:

Electronic documentation on over
150,000 machines, available in 28
languages



HOMAG Group AG
info@homag.com
www.homag.com

YOUR SOLUTION