



TECNOLOGY
FOR **SINGLE**
COMPONENTS

WHO WE ARE



From an important **group...**

Since more than 40 years, Ecoenerg operates in the electronic field, both civil and industrial. It deals with the production of civil and industrial electrical Systems / Automation / Home automation / VMC equipments / Hydraulic and Heating systems / Civil construction / Sustainable construction / Lighting industry (innovative technologies for energy saving) / Industrial automation / Control panels and cabins / Management and supervision of industrial plants and Building Automation / Software and systems for process control and production management / Techniques and solutions for energy efficiency (existing buildings) / Photovoltaics / Biogas / Biomass cogeneration.



... a great **expertise.**

Established in 2014, ECOLINE is a young company whose engineers and technicians are skilled in the sanding, brushing and finishing of wood surfaces since decades. The joint venture with ECOENERG ensures stability and resources, along with the expertise of our team.

Our technicians are highly specialized in providing technology to all those companies operating in the carpentry field or the aluminium, plastic and other composite materials processing, whether they are small artisans or large industrial groups.

Our technology, protected by more than ten granted patents, makes us leader in our field; we are able to produce Woodworking Machinery using standard technology as well as fully customized projects.

We are a reference all over the world for our customers thanks to our commitment in research.

Using the best materials available on the market, we combine mechanical steadiness and high industrial automation technology that means "reliability and long lasting performances".



PATENTED TECHNOLOGY



LEADER OF TECHNOLOGICAL INNOVATION



SERVICE AND PARTS



QUALITY AND DURATION MADE IN ITALY



ENERGY SAVING



SAFETY AT WORK



LABOR SAVINGS

INFORMATION GENERAL

PROFIL SAND

Finishing of **excellence**.

C.N.C. FINISHING CENTER FOR SANDING AND DENIBBING OF SINGLE PIECES OR PROFILES. THANKS TO 8 DIFFERENT WORKING UNITS PROFILSAND 8 PROCESS ALL SURFACES AND ANY KIND OF TIMBER: ROUGH, IMPREGNATED, OR LACQUERED.

Thanks to a fully automatized working cycle and high level of technology Profilsand guarantees high accuracy, fast and easy positioning of the working units.

- Steel structure ensures stability and strength.
- Ground working tables maintain parallelism with sanding disks.
- All adjustments of the operating units are on ball bearing linear guides to ensure long life, accuracy and high strength.
- Powered feed belts for the work-piece movement, feed speed driven by inverter.
- Pressure rollers all along the working process to ensure work-piece's stability.
- Pressure rollers coated with vulcanized rubber and provided with spring-loaded suspension.
- All working units provided with dust extraction.
- Cabin closes on six sides.
- Side doors provided with safety system, machine stops in case of door opening. Doors have windows to allow the control of the work-piece.
- Steel side reference guide of right hand machine entrance (zero reference).



WORKING PROCEDURE

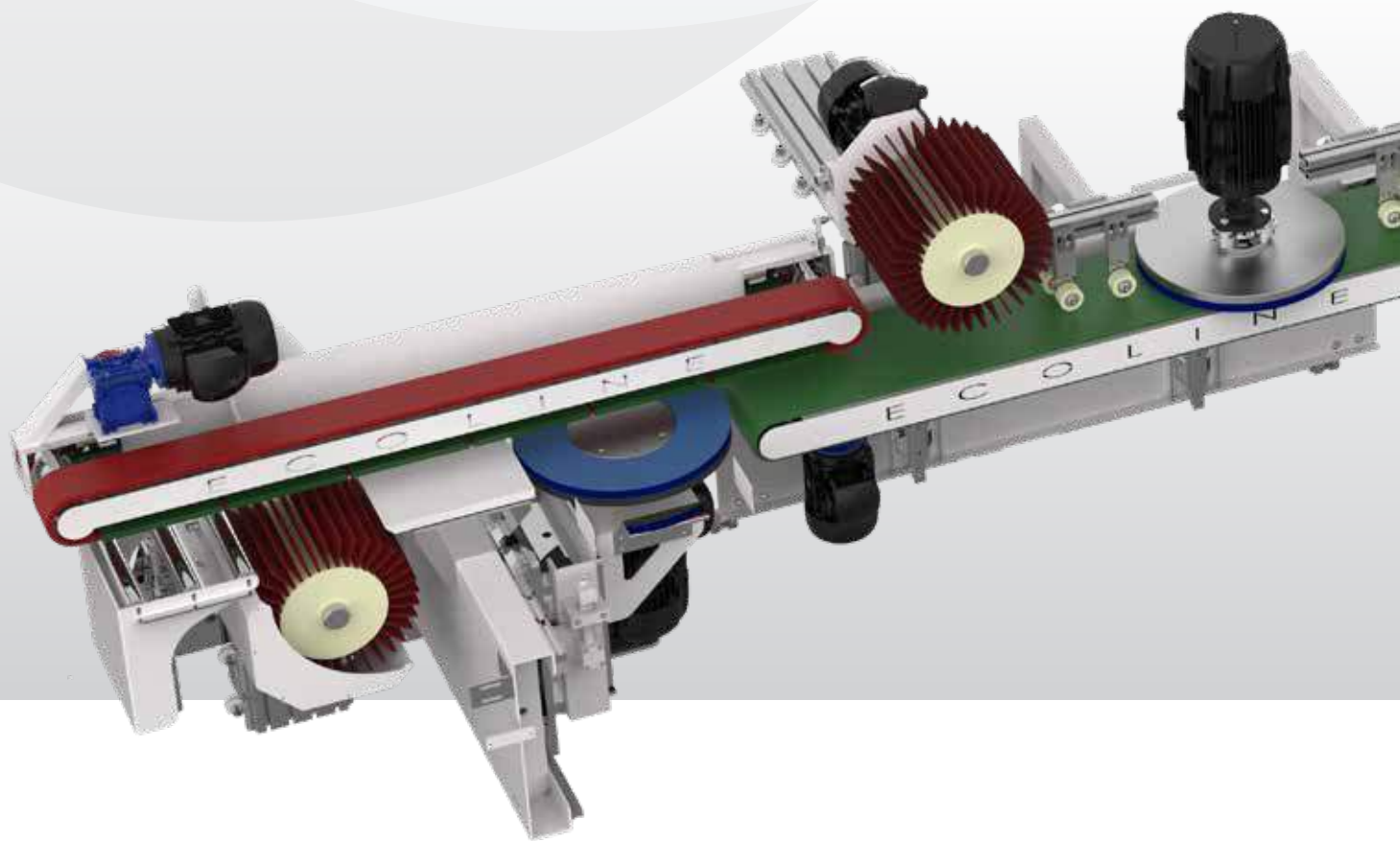

The working cycle is very easy thanks to the high level of automation. It is possible to summarize the working cycle in the following phases:

- Choice of pre-set working program.
- Working and pressure units adjust automatically according to the selected program and the parameters entered.
- The working cycle starts by setting work speed, the pressure of the units and rotating speed according to the selected program.
- All working units are driven by Inverter.
- All brushes and sanding disks are provided with individually replaceable abrasive strips or sandpaper.
- Thanks to the innovative Ecoline operating system, all working units ensure the maintenance of the work-piece geometry.

PROFIL SAND

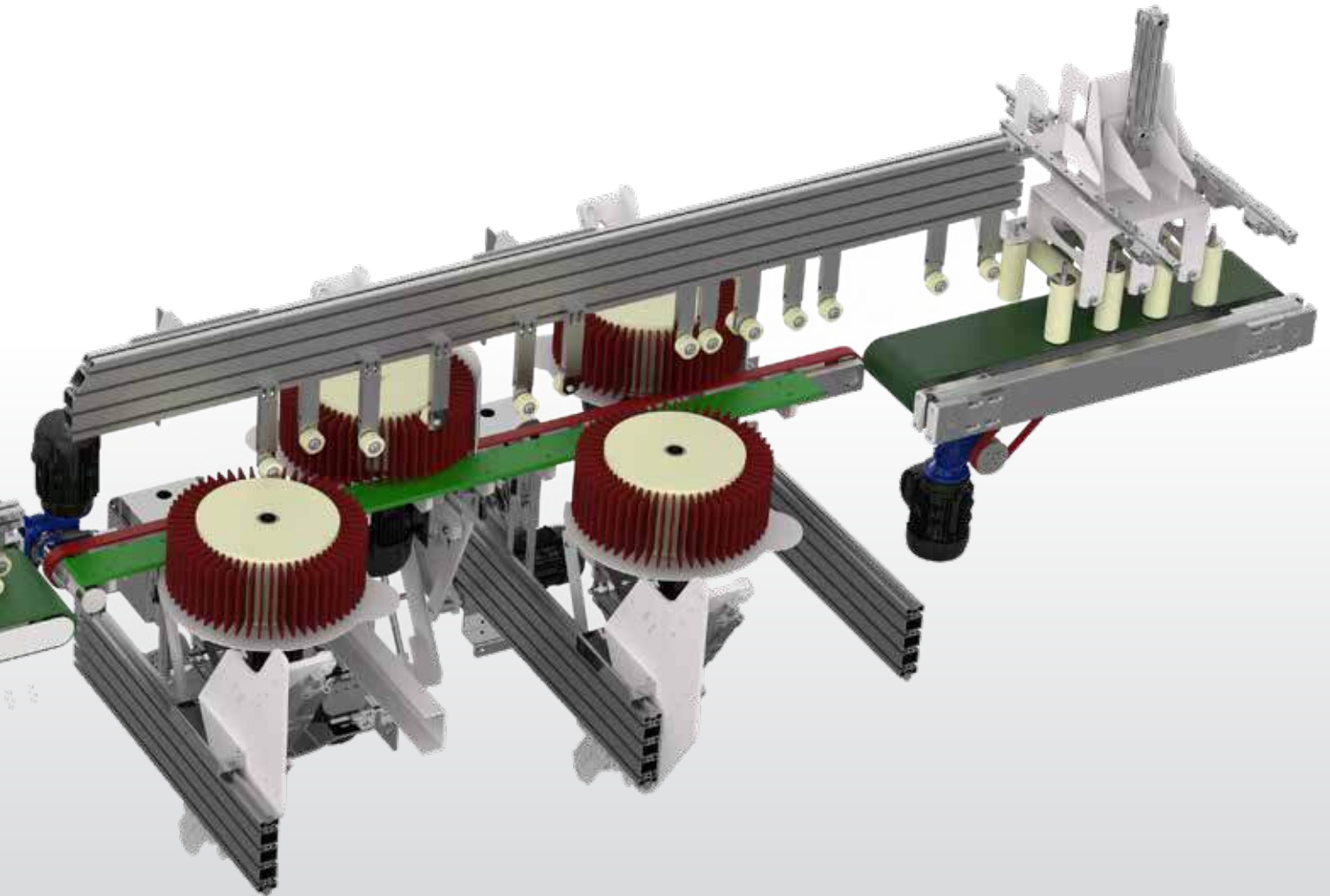

MACHINE CONFIGURATION

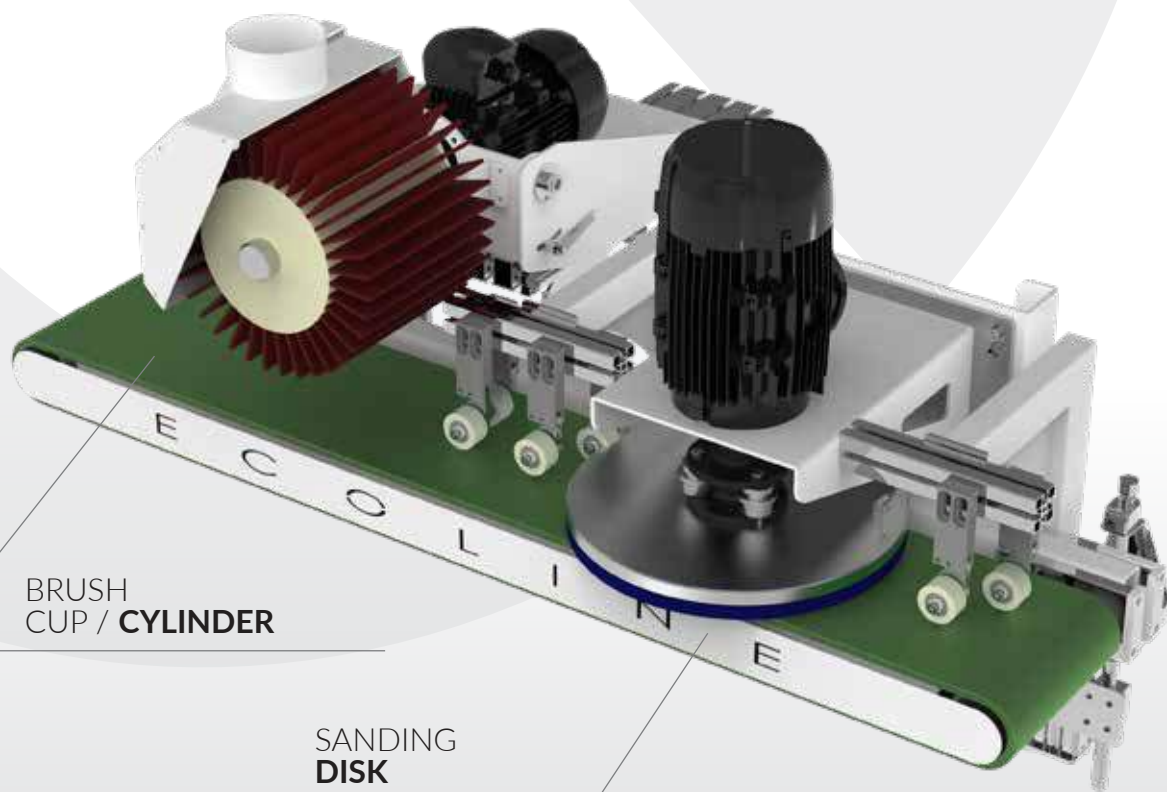

1

UPPER MODULE

CYLINDRICAL BRUSH Ø 400/420 mm or
CUP BRUSH Ø 270 mm

Cylindrical brush driven by 1.5 kw motor, electronically controlled variable rotating speed by inverter.

Vertical stroke 160 mm on linear guides, electronic adjustment according to workpiece thickness.

SANDING DISK Ø 400/420 mm

Sanding disk driven by a 1.5 kw motor, electronically controlled variable rotating speed by inverter.

Vertical stroke 160 mm on linear guides, electronic adjustment according to the work-piece thickness.

PROFIL SAND

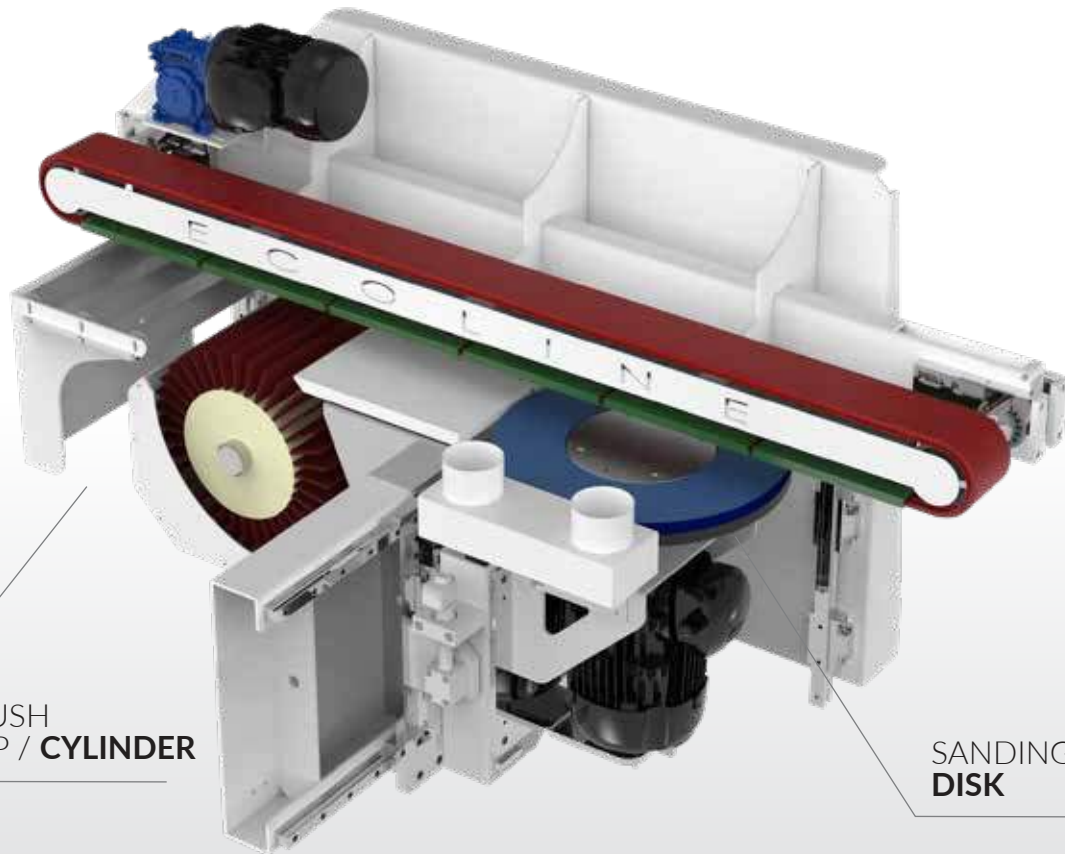

2

LOWER MODULE

CYLINDRICAL BRUSH Ø 400/420 mm oppure
CUP BRUSH Ø 270 mm

Cylindrical brush driven by 1.5 kw motor, electronically controlled variable rotating speed by inverter.

Adjustment of working effects on linear guides and positioning control by Siko reader.

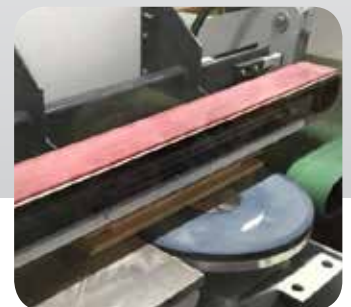

SANDING DISK Ø 400/420 mm

Sanding disk driven by 1.5 kw motor, electronically controlled variable rotating speed by inverter.

Adjustment of working effects on linear guides and positioning control by Siko reader.

Easier horizontal extraction for abrasive paper change easier.

MACHINE CONFIGURATION

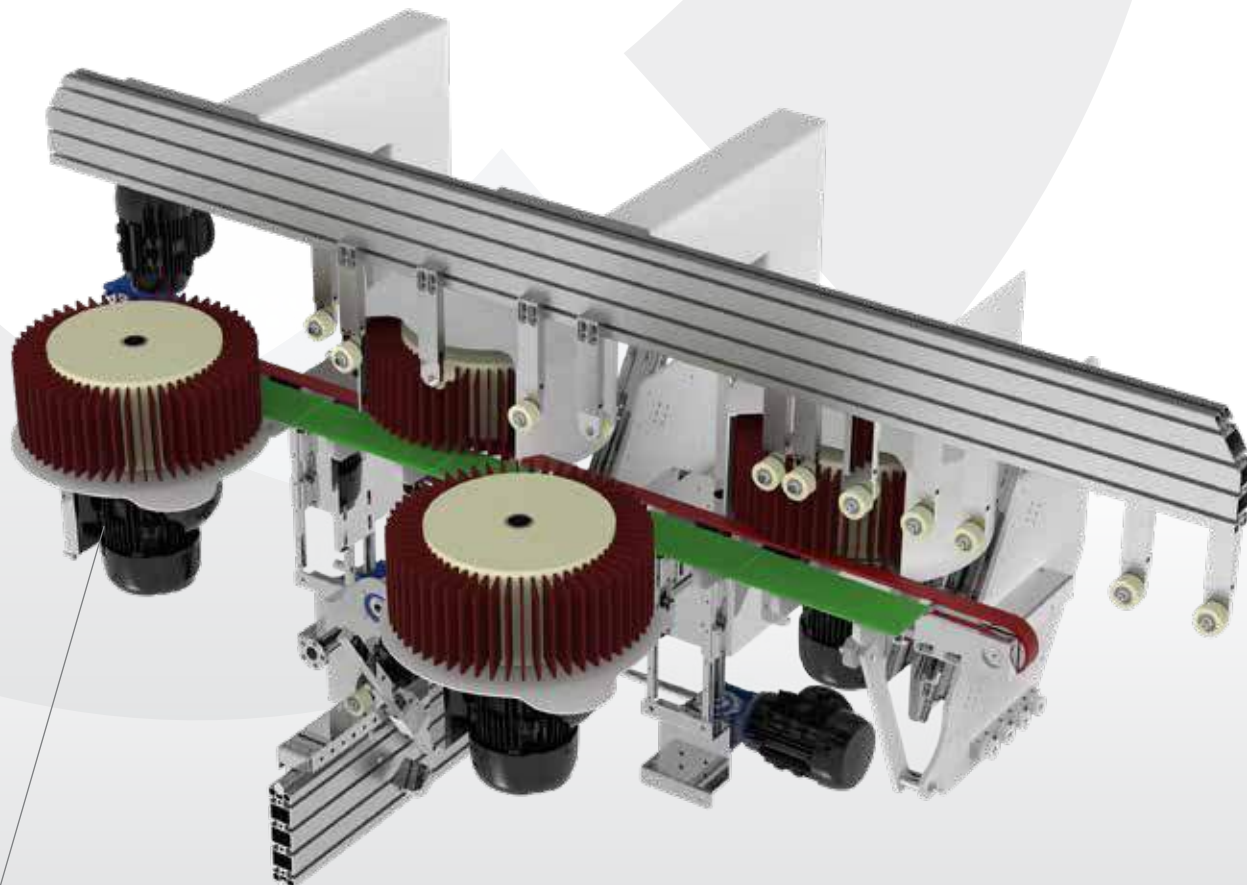

CYLINDRICAL
BRUSH

3 / 4

SIDE BRUSH MODULE

SINGLE: 1 + 1 CYLINDRICAL BRUSH (3)
DOUBLE: 2 + 2 CYLINDRICAL BRUSHES (4)

Right/left hand cylindrical brushes, 1.5 kw motor each, variable rotating speed driven by inverter. 3-position electronically



controlled automatic tilting: +35° - 0° - -12°.
Horizontal stroke adjustment on linear guides.

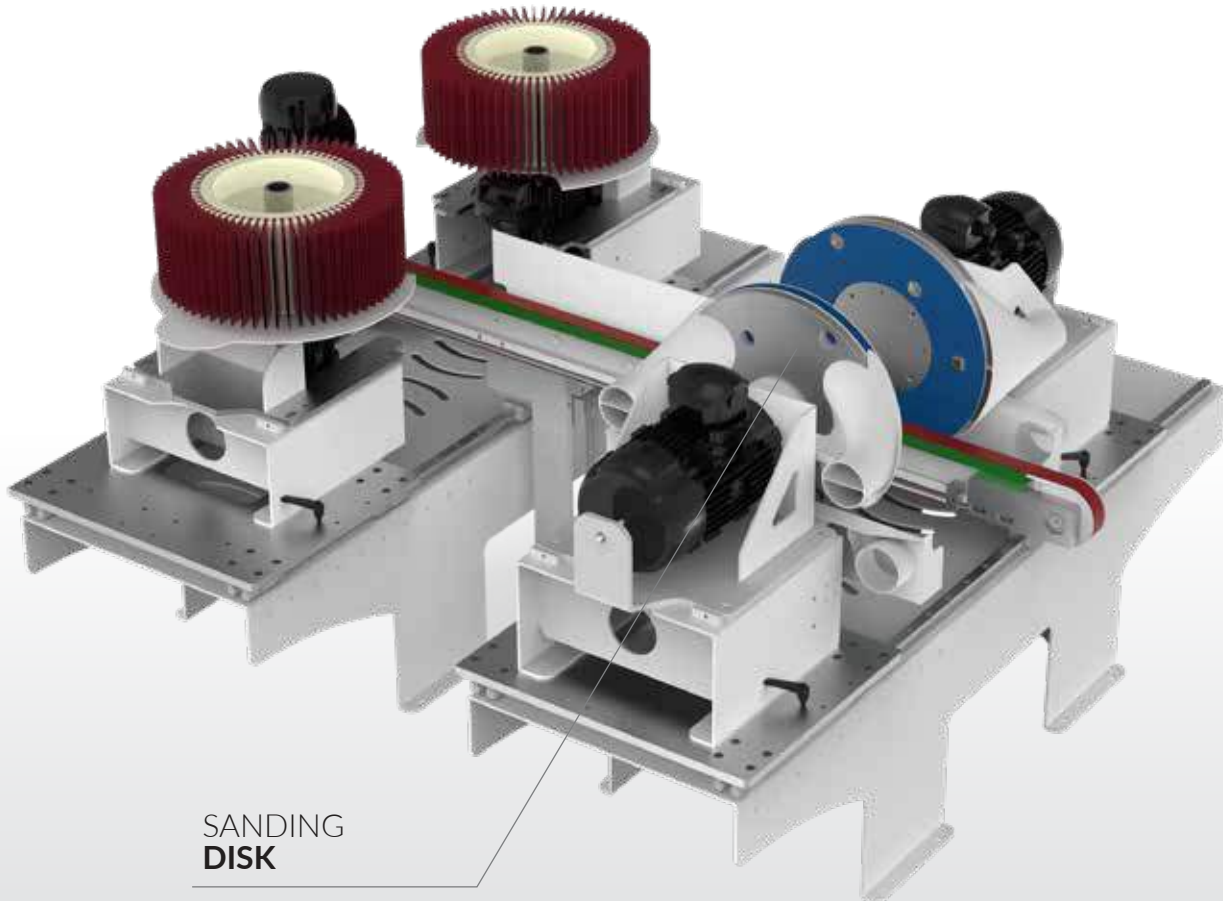

SANDING
DISK

5 / 6

SIDE SANDING MODULE

SINGLE: 1 SANDING DISK + 1 CYLINDRICAL BRUSH (5)
DOUBLE: 2 SANDIND DISK + 2 CILINDRTICAL BRUSHES (6)

sanding disk driven by 1.5 kw motor, electronically controlled
variable rotating speed by inverter.
Available automatic tilting adjustment.



Cylindrical brush, 1.5 kw motor each, variable rotating speed driven
by inverter. 3 - positions electronically controlled automatic tilting:
+35° - 0° - -12°.

ECOLINE SYSTEM

ADVANTAGES

- Labor cost cutting and healthy job.
- Excellent finishing results thanks to the fibre cut cross system.
- The high accuracy of sanding disk adjustment ensures excellent results on rough, impregnated, or lacquered surfaces.
- Fully automatized working cycle with fast positioning when the work-piece need to be change.
- Geometry of the workpiece's edges ensured by the electronic adjustment of working units.
- Steady worktable height allows the installation of the machine on working lines.
- High degree of feed and rotating speed modulation.
- Working units provided with an additional adjusting system to change the work pressure and compensate abrasive wearing.
- Low maintenance cost due to the possibility of replacing single abrasive strips.
- The fully closed cabin ensures almost zero dust emission and a complete safety for the operator.
- Easy maintenance and adjustments.

ACCESSORIES

- Electronic thickness laser measuring unit
- Right hand reference guide with retractable pneumatic movement
- Automatic horizontal adjustment of upper pressures
- Work-piece cleaner by blowers

HMI

Full PLC control.

Choice of programs and settings through colour touch screen.

Wide memory capability to save pre-set programs.

External USB support to export programs.

Large and understandable icons for easy and friendly use.

Automatic control of abrasive workload and replacement.

Remote after-sale service. (need of Internet connection).



PROFIL SAND

		PROFILSAND 4	PROFILSAND 4	PROFILSAND 6	PROFILSAND 6	PROFILSAND 8	PROFILSAND 8
Codes / GROUPS		SM 310 -000	SM 120 -000	SM 312 -000	SM 512 -000	SM 412 -000	SM 612 -000
Dimensions (length x width x height)	mm	3633 x 1740 x 1850	4703 x 1740 x 1850	4703 x 1740 x 1850	5070 x 1740 x 1850	5070 x 1740 x 1850	5070 x 1740 x 1850
Working table height	mm	875	875	875	875	875	875
Weight	kg	2000	3000	3000	3800	4000	3800
Operating voltage	V	400	400	400	400	400	400
Electric current	A	40	40	40	40	40	40
Electric power	Kw	7	11	11	15	15	15
Frequency	Hz	50	50	50	50	50	50
Electrical cabinet protection		IP 55	IP 55	IP 55	IP 55	IP 55	IP 55
Air connection		6 bar	6 bar	6 bar	6 bar	6 bar	6 bar
Dust extraction	mm	Nr 4 x Ø 120	Nr 6 x Ø 120	Nr 6 x Ø 120	Nr 6 x Ø 120	Nr 8 x Ø 120	Nr 6 x Ø 120
Workpiece dimension							
Shortest piece	mm	350	350	350	350	350	350
Max. width	mm	200	200	200	200	200	200
Min. thickness	mm	10	10	10	10	10	10
Max. thickness	mm	120	120	120	120	120	120
Equipment							
Certification		CE	CE	CE	CE	CE	CE
HDMI		Touch screen 11 inch	Touch screen 11 inch	Touch screen 11 inch	Touch screen 11 inch	Touch screen 11 inch	Touch screen 11 inch

1 UPPER MODULE
2 LOWER MODULE

3 SIDE BRUSH MODULE - SINGLE
4 SIDE BRUSH MODULE - DOUBLE

5 SIDE SANDING MODULE - SINGLE
6 SIDE SANDING MODULE - DOUBLE



Via Ceratelli, 2 - 46043
Castiglione d. Stiviere (MN) - Italy
Tel. +39 0376. 1514601 / 609

info@ecoline.info
www.ecoline.info