

SAWTEQ

S-200 / S-210

Performance tailored to your needs.
Our panel dividing saw

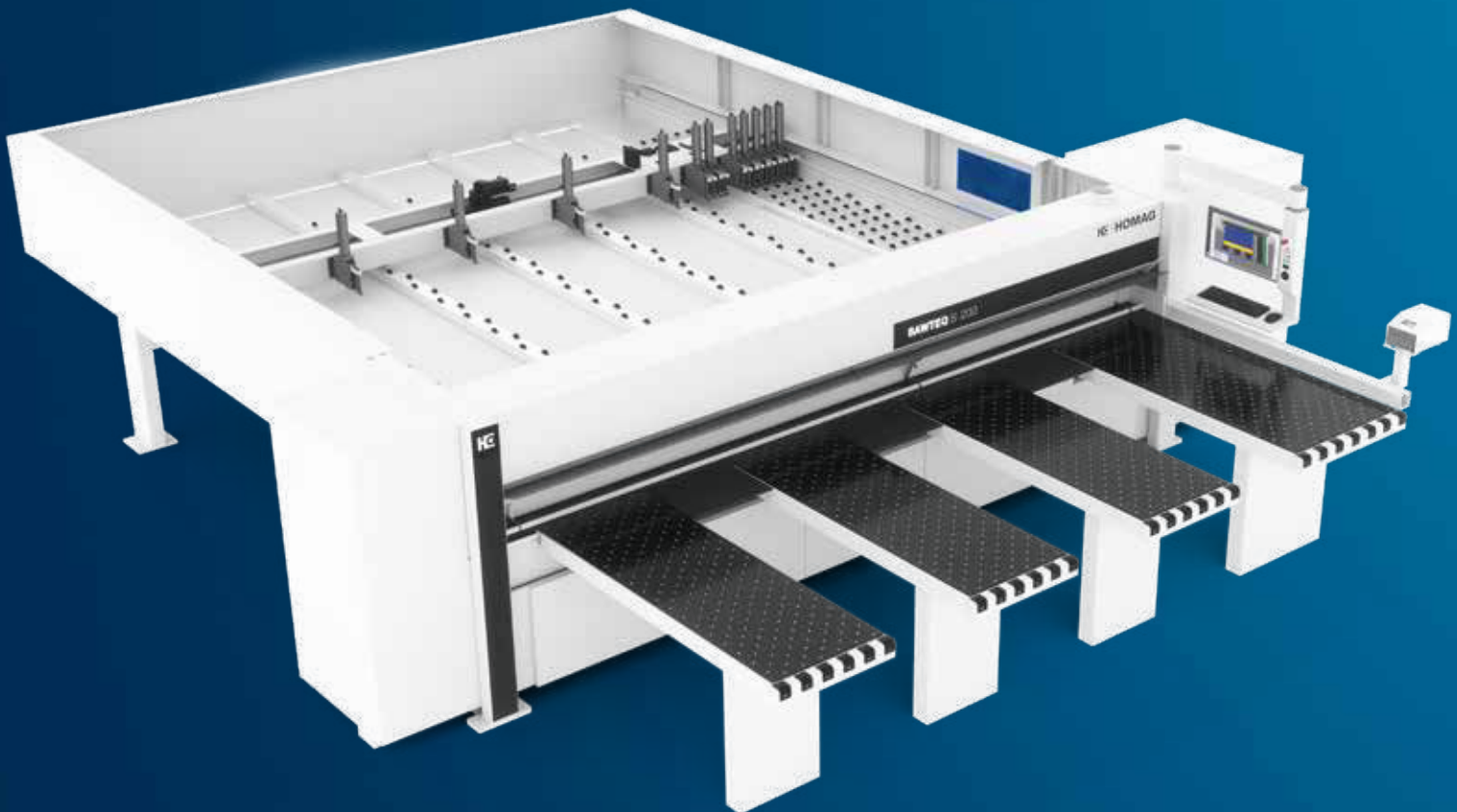



SAWTEQ S-200 / S-210 – and your cutting operations are as versatile as your craft

The SAWTEQ S-200 / S-210 offers everything you need in a woodworking shop to cut panels horizontally: power, precision and above all flexibility. This begins with the technology: the SAWTEQ S-200 / S-210 offers you a choice between two standard models and a wide range of technology options, allowing you to customize your machine to meet your specific requirements. You remain flexible and have a saw that can grow with your needs.

YOUR SOLUTION

MORE AT HOMAG.COM



SAWTEQ S-200 / S-210

CONTENTS

- 04 Software
- 12 SAWTEQ S-200 single saw
- 14 SAWTEQ S-210 saw with lifting table
- 16 Standard features
- 22 Optional features
- 37 Technical data
- 38 Service



CADmatic 5 – intuitive to operate and open for digital networking

CADmatic 5 is the state-of-the-art, high-performance saw control system from HOMAG. A wide range of functions and easy to handle. This is ensured thanks to the intuitive operating concept and clear administrative functions. What's more, CADmatic 5 is open for communication with other machines and software solutions.

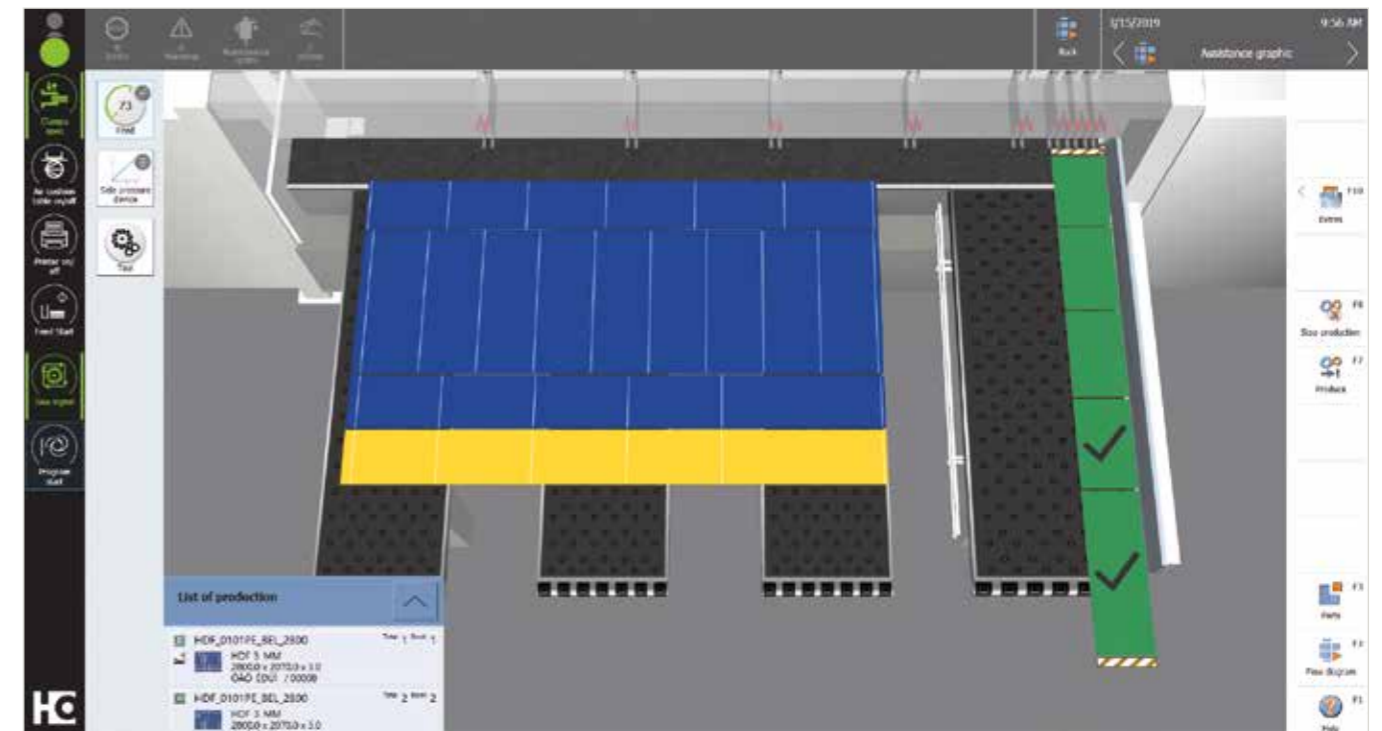

CADmatic 5 – the change in perspective

The latest generation of the HOMAG saw control system has a 3D assistance graphic that clearly shows the machine operator all the cutting steps in order. It can be operated intuitively, which shortens the training time and reduces errors to a minimum.

Highlights:

- Simple, intuitive and ergonomic machine operation thanks to the 3D assistance graphic
- This results in efficient processes and a steady output
- 24" swiveling full-HD multi-touch display in widescreen format is easy to use by swiping, scrolling and zooming
- Uniform operating concept thanks to the powerTouch user interface
- All HOMAG saws with CADmatic 5 are automatically tapio-ready

Find out more in the "CADmatic" brochure.

What's the difference? The software!

It efficiently integrates the machine into the production process. This results in seamless, intelligently networked processes from start to finish. In short: the right software unlocks new value-added potential. That is what makes it so important.

Next generation of powerTouch: **powerTouch2**

Faster, clearer, easier to use: Enjoy the benefits of our further improved powerTouch user interface. We have optimized our standardized operating concept and further adapted it to our customers' needs. You can now control your HOMAG machines more quickly and more intuitively. The new, modern design is clearly structured. The innovative touch operation is designed to enable you to get the desired result easily and comfortably.

With the new powerTouch generation, you can enter information on the machine more quickly. Compared to the previous version, you can achieve a time saving of up to 30%. This is possible thanks to new features, such as auto-complete, a pop-up keyboard that can be kept open and Windows-like functions, such as the selection of common actions directly via the start button.

Our successful powerTouch philosophy—**simple, standardized, ergonomic, evolutionary**—systematically enhanced

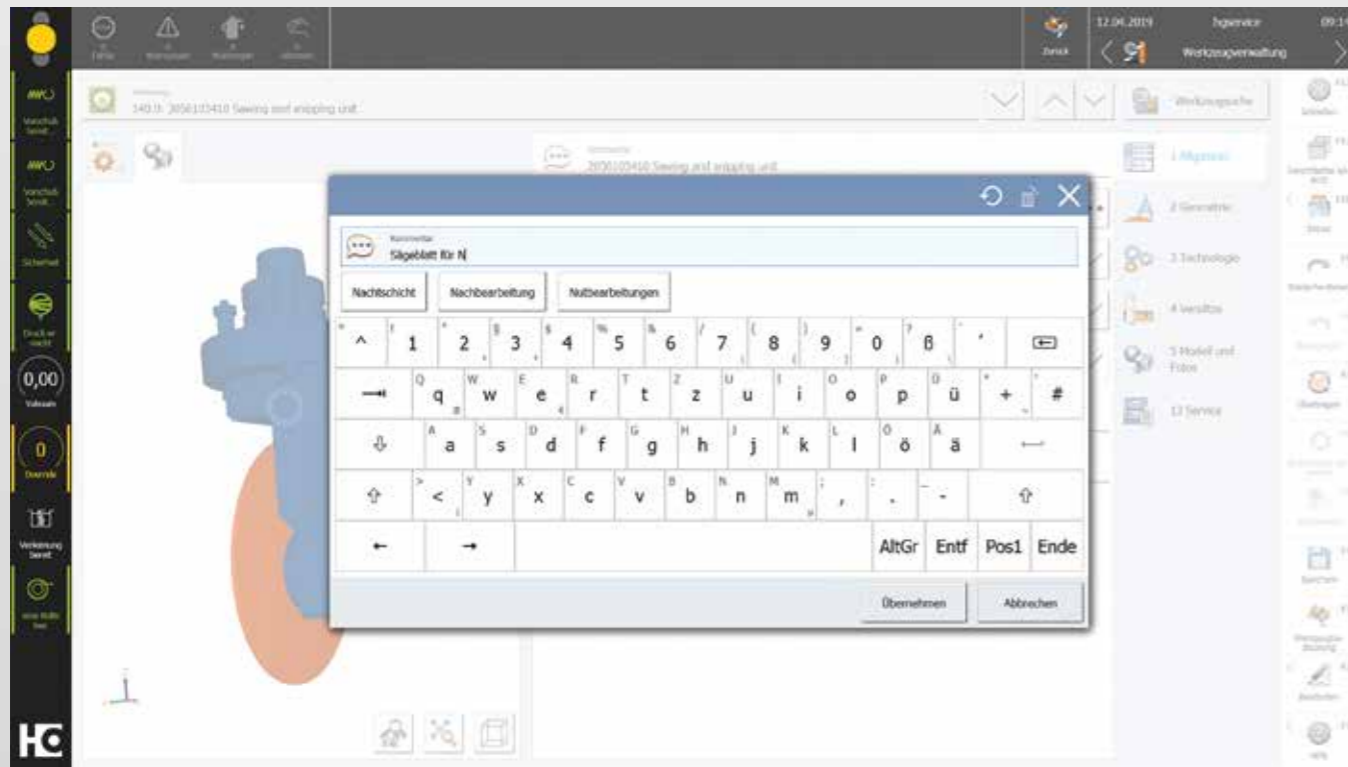

1 The powerTouch2 screen is clearly laid out and logically structured. You can see all the main information at a glance, but you still have all the details.

3 Functional pop-up keyboard that can be kept open, including auto-complete for faster input (when you enter the first few letters, frequently used applications are suggested and you can select them directly).

2 We have also improved the traffic light dialog again. You can now directly influence the machine's production readiness by selecting actions via the traffic light icon.

4 Enhanced "Start" menu that displays additional information (e.g. indicates how many messages there are, or has status bars that show how far the application has progressed) and allows actions to be called up directly (e.g. confirm actions without having to go to the application).

Apps and digital assistants.

Quick and easy support in the machine environment.

Some people still use pen and paper to create their cutting patterns. But they look at their smartphone if they want to know what the weather is like — instead of looking out of the window. We asked ourselves: why not combine the best of both? Our apps and digital solutions make your everyday work easier: machines, material, tools, cutting patterns, components — you always have everything in your pocket or on your desk.



More information at digital.homag.com



WE HAVE DEVELOPED POWERFUL AND SMART SOLUTIONS FOR YOU:

- ✓ Always low investment
- ✓ Always up to date (no updates necessary)
- ✓ Always easy to use (no complex software)
- ✓ Always helpful

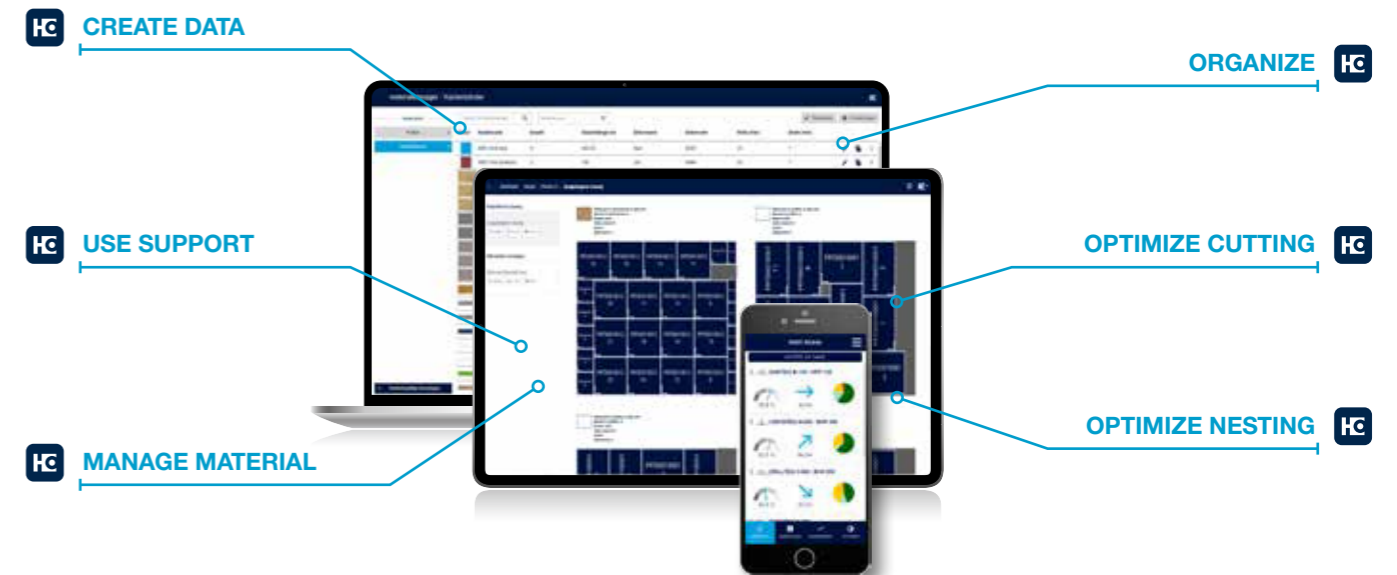

Optional feature: innovative operator guidance with IntelliGuide Classic

The IntelliGuide innovative operator assistance system is now available for the SAWTEQ S-200 / S-210. The Classic version features an LED strip at the cutting line which guides the operator by means of light signals.

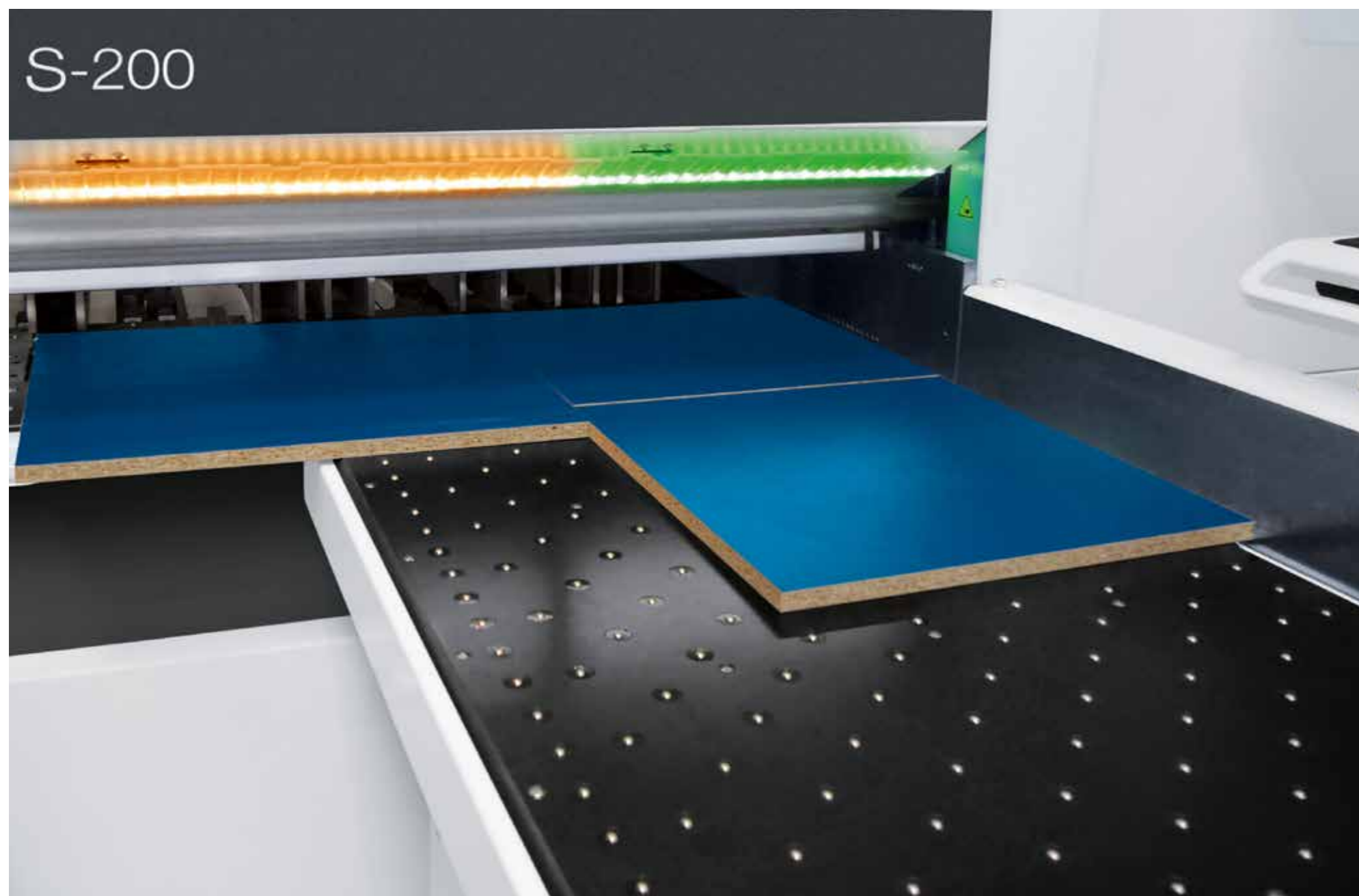

IntelliGuide Classic at a glance

- Colored LED signals at the cutting line allow intuitive operation and a quicker, safer way of working
- Using the colored LED elements, machine operators can immediately see if a part has been fully processed, needs to be cut again or can be disposed of as a waste part
- On the basis of the LEDs that light up, the operator can determine whether the workpiece on the table meets the required specifications

Would you like more information? Find out more in the "IntelliGuide" brochure.

Benefits of the IntelliGuide Classic

- Quick and easy processes: Operator and saw work in tandem and do not slow each other down
- The machine is intuitive to operate thanks to colored LED signals: The operator rarely has to look at the monitor, which allows the cutting pattern to be processed in a concentrated manner
- Smooth, ergonomic and safe processes for efficient working
- Easy to change operator at any time



CADmatic 5 Classic destacking module

Which component goes where? The integrated destacking display of the Classic destacking module provides the answer to this question. The individual parts are color-coded both in the cutting pattern and in the assistance graphic. This means that the machine operator can clearly see which of the parts already produced have been allocated to which destacking stations.

Optional features: increasing productivity with the appropriate cutting optimization software

Production time, material yield, parts handling and logistical process: efficient panel cutting with seamless processes requires intelligently optimized cutting patterns. For HOMAG saws, you can get the appropriate optimization solution on demand – from large to small, as permanently installed software or directly from the tapio cloud. You have the choice because the SAWTEQ S-200 / S-210 is, like all HOMAG saws, tapio-ready.

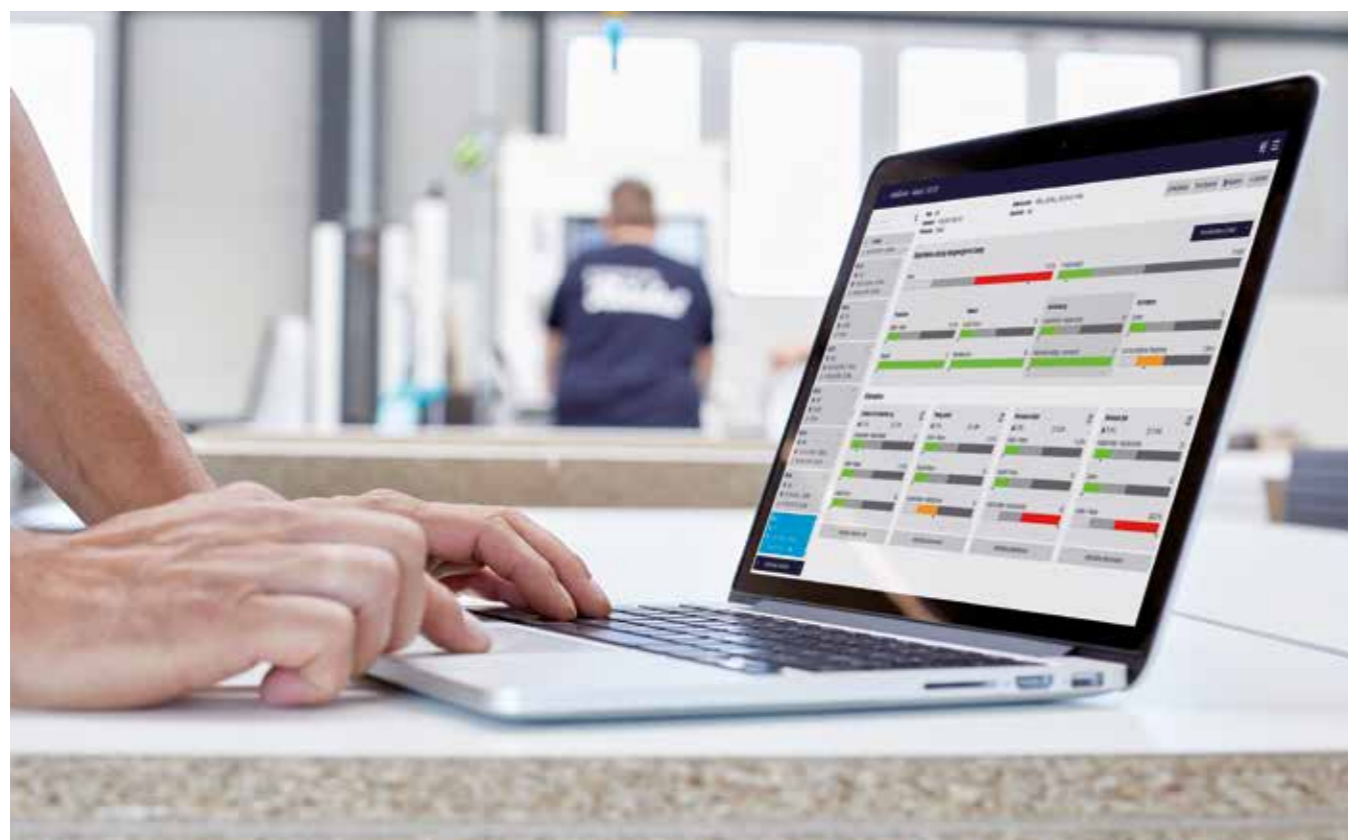

intelliDivide – the easy way to first-class optimization results

Simply upload the parts list. Done! The result? A choice of several alternatives for cutting patterns and entire runs. That's how easy intelliDivide makes it.

In detail: the cloud-based optimization software intelliDivide utilizes significantly higher computing capacities than are available for locally installed optimization software and can therefore swiftly provide the user with several alternative optimization results.

This means that with intelliDivide the operator can choose from a variety of options, including results based purely on reducing waste, on the shortest machine time or on the simplest handling, perfectly adapted to the relevant requirements.

Applications are varied and are geared toward both woodworking shops and industry.



Cut Rite cutting optimization software

Efficiency through planning: This short phrase sums up the key benefits of the Cut Rite software. With this world-leading software solution, you can optimize waste and systematically lower the overall costs for cutting.

Highlights

- Seamless, precise and highly efficient processes ensure optimized project control
- Efficient cutting processes which can be individually adapted to your production processes using parameter settings
- Full cost control within the cutting process: material costs and processing time are calculated automatically when the quotation is prepared
- Faster calculations by using all the processors in the PC
- Simple handling: clearly structured, easy to operate and graphics display the information

Find out more in the "Cut Rite" brochure.

SAWTEQ S-200

With the SAWTEQ S-200, you are choosing a saw that stands for precision and flexibility in cutting processes. Ideal for woodworking shops and always ready for more.

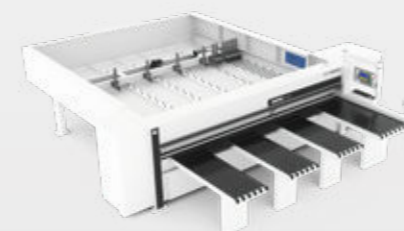

The highlights

- 65 mm saw blade projection and a choice of even 80 mm or 95 mm
- HOMAG CADmatic5 control software
- New: Power Concept Classic for even more performance and throughput



SAWTEQ S-210 with lifting table

The SAWTEQ S-210 can be equipped with an integrated lifting table for program-controlled feeding from the rear. This is significantly more ergonomic, faster and more efficient than feeding solely manually from the front.

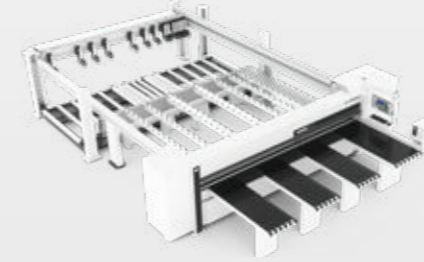

The highlights

- 65 mm saw blade projection and a choice of even 80 mm or 95 mm
- HOMAG CADmatic 5 control software
- Power Concept Advanced for even more performance and throughput



ecoPlus – because efficiency starts with the use of resources

Energy, time, material and personnel are all precious resources. Conserving them increases productivity and saves costs. ecoPlus technologies from HOMAG help you to achieve this, providing countless innovations that save energy and reduce your operating costs. What's more, ecoPlus reduces CO₂ emissions and protects the environment. A worthwhile investment twice over.

ECOPLUS TECHNOLOGIES FOR MAXIMUM ENERGY SAVINGS

- The standby button – a standard feature – puts the saw in an energy-saving standby mode at the touch of a button
- SAWTEQ S-200 / S-210 with IE3 motors
- Variable speed control by means of a modern bypass circuit for all models with frequency-controlled main saw motor
- The geometry of the saw carriage enables highly efficient dust extraction
- All models are equipped with an energy monitor for monitoring consumption
- Less energy required thanks to optimized suction device



- Thin-cutting saw blades can be used on request, ensuring reduced waste and providing other benefits
- Many innovations for improved ergonomics and seamless production processes

Standard features

Mechanical engineering of outstanding quality and state-of-the-art technologies are standard for the SAWTEQ S-200 / S-210. This is admittedly an exceptionally high standard in this performance class, but then, after all, it is not without good reason that you choose a HOMAG saw.

The standard version is more than the sum of its parts

Whether it's the patented side pressure device or the robust HOMAG clamps: the standard version of the SAWTEQ S-200 / S-210 offers impressive leading-edge technologies for your production process.



Program fence for precision and dimensional accuracy

The compact, electronically controlled program fence with clamps and precision guides has an electro-magnetic measuring system that guarantees positioning accuracy of +/- 0.1 mm per meter – at travel speeds of up to 80 m/min. Even minimal trims and dust cuts are possible. The measuring system is entirely wear- and maintenance-free.

Rugged pressure beam for first-class cut quality

The large-area pressure zone directly at the cutting line reduces vibrations to a minimum. The result is precise cuts, for books too.



Additional start/stop key

A very practical and ergonomic solution – in particular when cutting long strips or large panels that make access to the control panel difficult.



Clamps: perfection down to the last detail

The robust HOMAG clamps position the material carefully and precisely at the cutting line. The clamps in positions 2 and 4 are available as an option.



Manual pressure control

The SAWTEQ S-200 / S-210 comes as standard fully prepared for cutting pressure-sensitive panels. You can adjust the pressure of the clamps and the pressure beam to suit your particular panel material by simply using the two manual controls conveniently located in the front operating area.

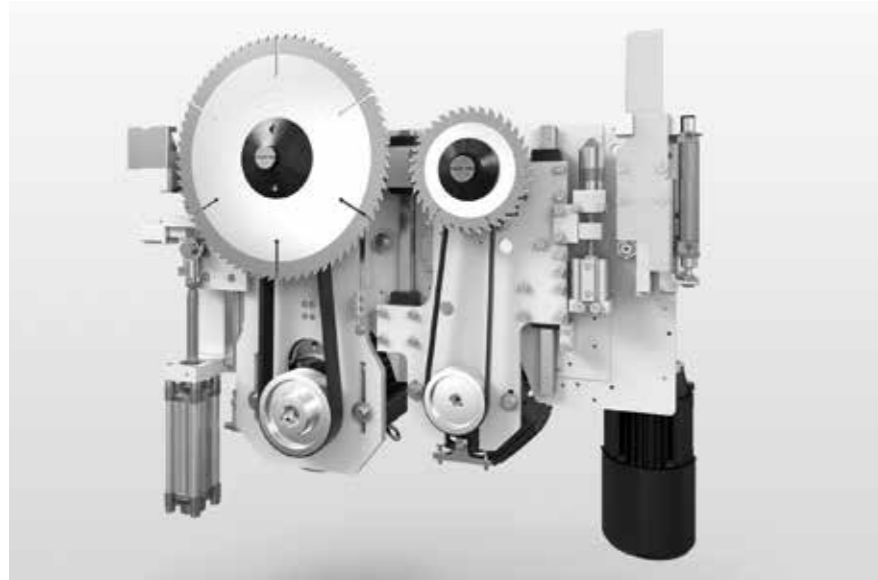

Saw carriage

The saw carriage is a robust steel construction with a main and a scoring saw as well as a central side pressure device.

- Infinitely variable saw feed speed
- High-precision, quiet and maintenance-free
- Saw carriage speed up to 120 m/min (optional)
- Equipped with IE3 motors
- Fast saw blade change thanks to Power-Loc



Power-Loc

This quick-release system is very easy to use and speeds up blade changes on both main and scoring saw.

- Automatic adjustment of scoring saw blade

HOMAG patent: central side pressure device

- Integrated directly into the saw carriage. This reduces the cycle times by up to 25% in comparison with conventional systems
- The contact pressure is infinitely variable – ideal for thin panels, laminates or sensitive materials

MORE AT HOMAG.COM



Central side pressure device



Power-Loc

SAWTEQ S-200 / S-210 with lifting table – equipped for higher throughput

HOMAG saws with lifting table go some way toward automating feeding and are therefore equipped with additional technical solutions even in the standard version.



Powerful feeding system

- Panels are fed via an electro-hydraulic four-column lifting table
- Automatic determination of book height
- Equipped as standard with longitudinal profiles and sensing device
- Maintenance-free and no lubrication required

Separate backing wall

The backing wall is not attached to the machine bed, ensuring precise cuts. This is because vibrations caused by the movement of stacks on the lifting table are not transferred to the machine bed.

Feeding solutions and storage solutions ranging from S to XXL

Manually transporting panel material from the shelf to the saw is time-consuming and often not ergonomic. This is just one of the reasons why automation solutions from HOMAG pay off within a short time. Furthermore, they save a lot of space and are available for almost every size of company. The spectrum of solutions ranges from the basic feeding system via the lifting table through to the large-scale storage control connection to the STORETEQ P-300 and P-500. In addition, all SAWTEQ S-200 / S-210 saws are open for connection to virtually all storage systems. This ensures the very highest level of performance.



Optional features

Special challenges call for special solutions. Nothing could be easier: simply choose the appropriate optional features and configure your SAWTEQ S-200 / S-210 to meet your specific production requirements. So you get precisely your solution.

Made-to-measure feeding solutions – for saws without lifting table

Smoothly running cutting processes begin with individually customized feeding solutions. The choice is yours!



Easy2Feed

Easy2Feed promises automatic feeding at a budget price. This optional feature saves time and space, is very ergonomic and can be retrofitted. The core element is a compact scissor lift table, which can be comfortably loaded by forklift truck.

- Panels upward of 9.5 mm thickness can be fed
- Maximum panel size:
For cutting length 3800 mm: 3100 x 2200 mm
For cutting length 4300 mm: 3660 x 2220 mm
- Stack height 460 mm (standard version)
- Lifting table in pit on request
- For material that can be push-fed
- Feed roller conveyor on the side available as an option

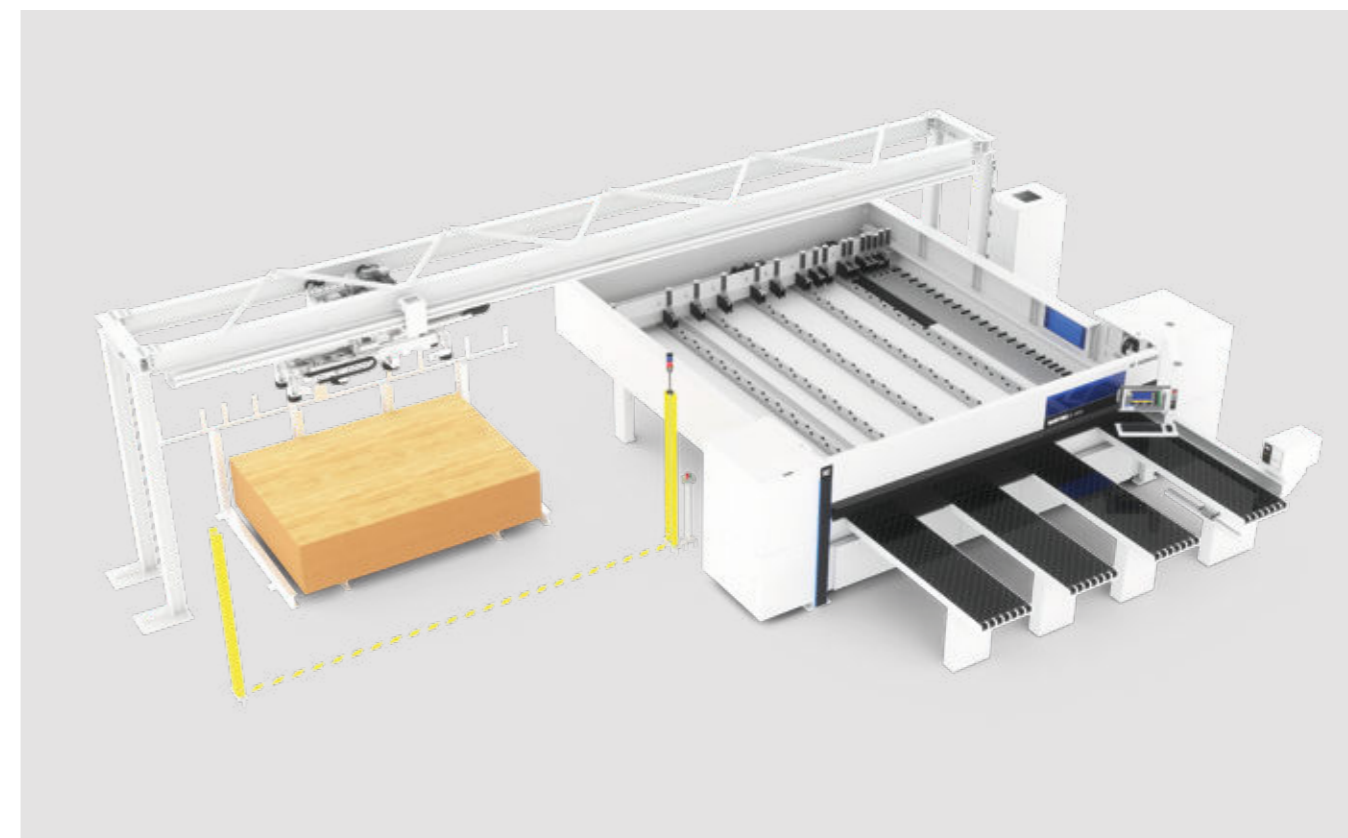

The HOMAG F-100 single-axis feeder increases your productivity (only for single saws without a lifting table)

Efficient, ergonomic, material-friendly: the new HOMAG F-100 single-axis feeder is an asset to every aspect of the production line and it does not take up much space either. Control directly at the saw via woodStore is particularly intuitive and simple. In conjunction with the SAWTEQ S-200, this creates a complete woodworking shop cell — including offcut management. Using vacuum suction units, the gantry fetches the next panel required from the stacking position adjacent to or behind the saw, turns the material if needed, and then places it in the saw, all on a just-in-time basis. All fully automatically.

Your benefits at a glance:

- **Speed up your feed:** The integrated complete solution leads to significantly higher saw performance. Additional benefit: Less time for sawing means more time for other value-adding activities.
- **Fully automatic panel handling:** A continuous process increases your productivity and saves time.
- **Optimized transport:** The single-axis feeder secures your panel quality.
- **Fits into any workshop:** The space-optimized feeder requires hardly any installation space.
- **More ergonomic:** The automatic feed makes work easier.
- **Standard interface:** All machines are already configured and ready for use — without any additional service support.
- **Intuitive operation:** Directly integrated in the saw control system, very conveniently via woodStore.

Standard features

- Basic frame in gantry design
- Movable lifting device with suction crossbeam
- Turning unit – rotatable up to 90 degrees
- Automatic weight detection
- Automatic length adjustment of the suction crosshead

Optional features

- Stacking positions available in 3,200 mm or 4,200 mm board length
- Additional storage places possible
- Expandable up to 8 stations, of which
 - maximum 3 processing machines
 - maximum 4 storage places
- Additional control panel for several integrated machines

Growing together. The all-in-one solution for your panel storage.

Whether it's a wide range of parts, high speeds or full equipment: the new storage range combines the strengths of automation with intelligent logistics. In order to enable an optimum storage control connection, we have expanded the design of the storage platform for the STORETEQ P-300 and P-500 storage systems — with a second-level STORETEQ P-310 and P-510 storage system and a STORETEQ P-320 and P-520 double-level storage system. The storage systems represent intelligent logistics with noticeable optimization effects — above all in the greater reliability, availability and standardized data integration and processing. This is achieved through the consistent use of the leading woodStore storage software.

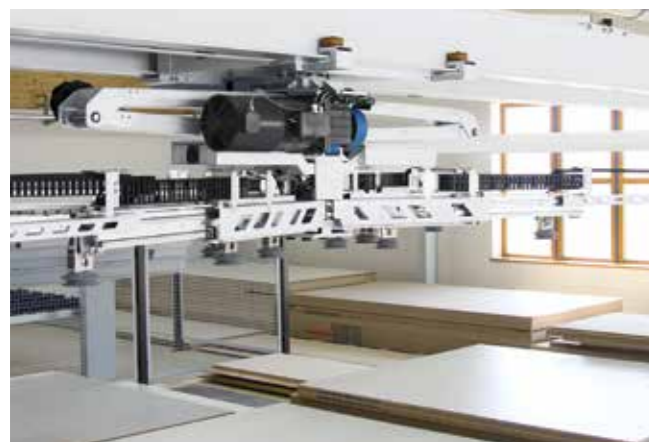
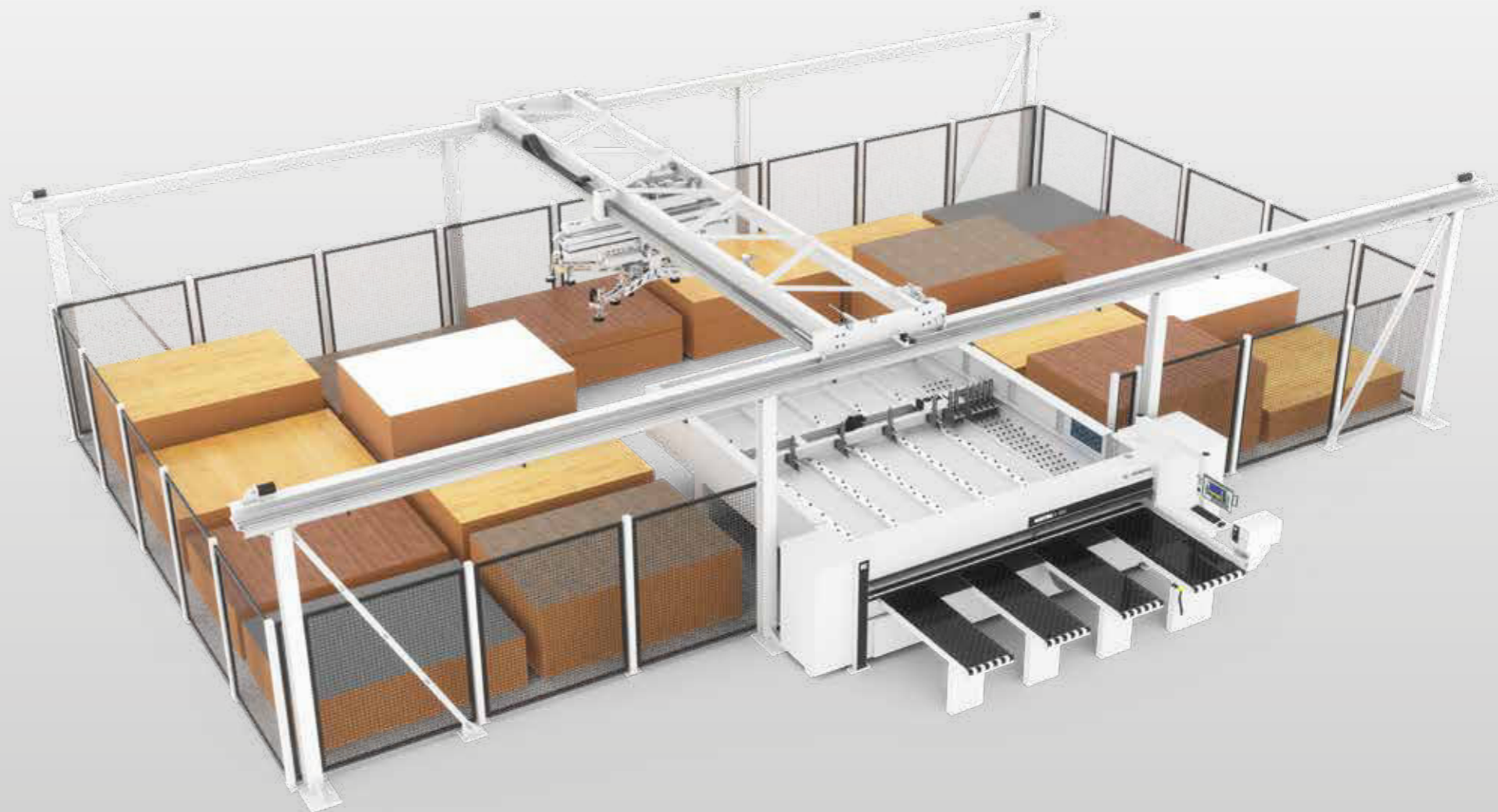

The **ST71 suction cross rail** in X geometry is the ideal optional feature for the panel storage. The self-learning cross rail generates the data required for panel handling independently and thus ensures dependable process reliability. The operator does not have to enter anything.

The HOMAG storage systems optimize your storage area and save valuable production space

- One software, all options: the woodStore storage software grows with your requirements
- No compromise: configure the solution that best suits you
- Intelligent standby – the machine only uses energy when it is actually moving
- Optimal material consumption right down to offcuts thanks to well-thought out material management
- Handling without any extra costs – coated panels from a thickness of 3 mm thanks to the ST 61 suction traverse, which is already included in the standard version
- Perfectly coordinated: ideal use of the given space – without expensive hall extensions
- Complete solution from a single source — including saw, nesting machine, storage platform and software



Great variety of materials

Whether it's handling plastic, plexiglass or laminate, coated or uncoated panels, the STORETEQ P-500/P-510 is also a true all-rounder when it comes to handling panels.

- Panel weights up to **350 kg** and panel lengths up to **5600 mm**
- Smooth transport of even textured surfaces
- High double scissor stability for precise panel handling
- Handling of plastic panels



STORETEQ P-500/P-510/P-520 — flexibility and variety of materials combined in one storage system

The sturdy construction of the STORETEQ P-500/P-510/P-520 allows a great deal of flexibility when designing the system's length and width.

- Span widths of up to **16 m** and travel path lengths of up to **100 m**
- Controlled, low-vibration movements even in the largest version



Ten important reasons to opt for the woodStore storage control system

1. Open database system enables seamless integration
2. Multi Terminal offers transparency and ergonomic operation
3. Smart Connected System: optimization, processing machine and storage are fully integrated into one cutting system
4. intelliStore: flexible storage organization that automatically adjusts to production conditions
5. Complete offcuts management prevents the buildup of offcuts
6. Forklift operator management: enables material supply separate from cutting
7. Management of outside storage is integrated
8. Easy Edit production lists: easy to change orders and sequence
9. Various storage strategies enable easy adjustment to production scenarios
10. Optimization of the production sequence enables high performance

woodStore 8. Portable, networked, user-friendly.



Mobile operation

Various functions can be controlled via mobile end devices connected within the machine's WIFI network.



User management

Personnel-controlled storage operation with a functional range of up to 40 different user rights.



Smart Connected System

Complete integration of optimization, saw and storage into one cutting system with corresponding standardized interfaces.



Email notification

In the event of any malfunctions in the operation of the storage system, the system sends an email to the email account specified.



Database access analysis

Customer database is measured for performance and logged to identify digital bottlenecks.



Smart Separation Learning

Fully automatic panel separation that requires only two panel handling settings.

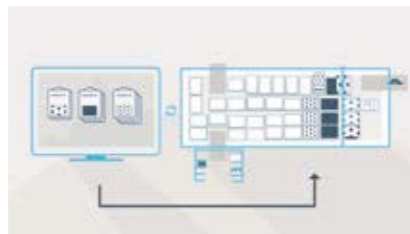

intelliStore

All storage movements are monitored permanently and automatically adjusted to the current production conditions.



Integrated image database

Easy selection and assignment of panel finishes for realistic representation of the panels available in the storage.



Scrap management

Automatic return of saw offcuts to storage with built-in panel measurement as part of the material intake process and management of manual offcut stocks with corresponding wizards for easy set-up.



woodStore Analyzer

In a period that can be selected individually, the main functions of the storage system are examined and analyzed according to the customer's requirements in order to determine whether the customer is using the storage system optimally.



Intelligent logistics are a key to success

HOMAG storage systems are intelligent all-rounders that meet all your needs. From the smallest storage "that would fit into a double garage" to the multi-story storage that would meet industrial requirements. Across all levels of production, the flow of material is optimized, stocks are managed in a transparent way and processing machines are used in an optimal way.

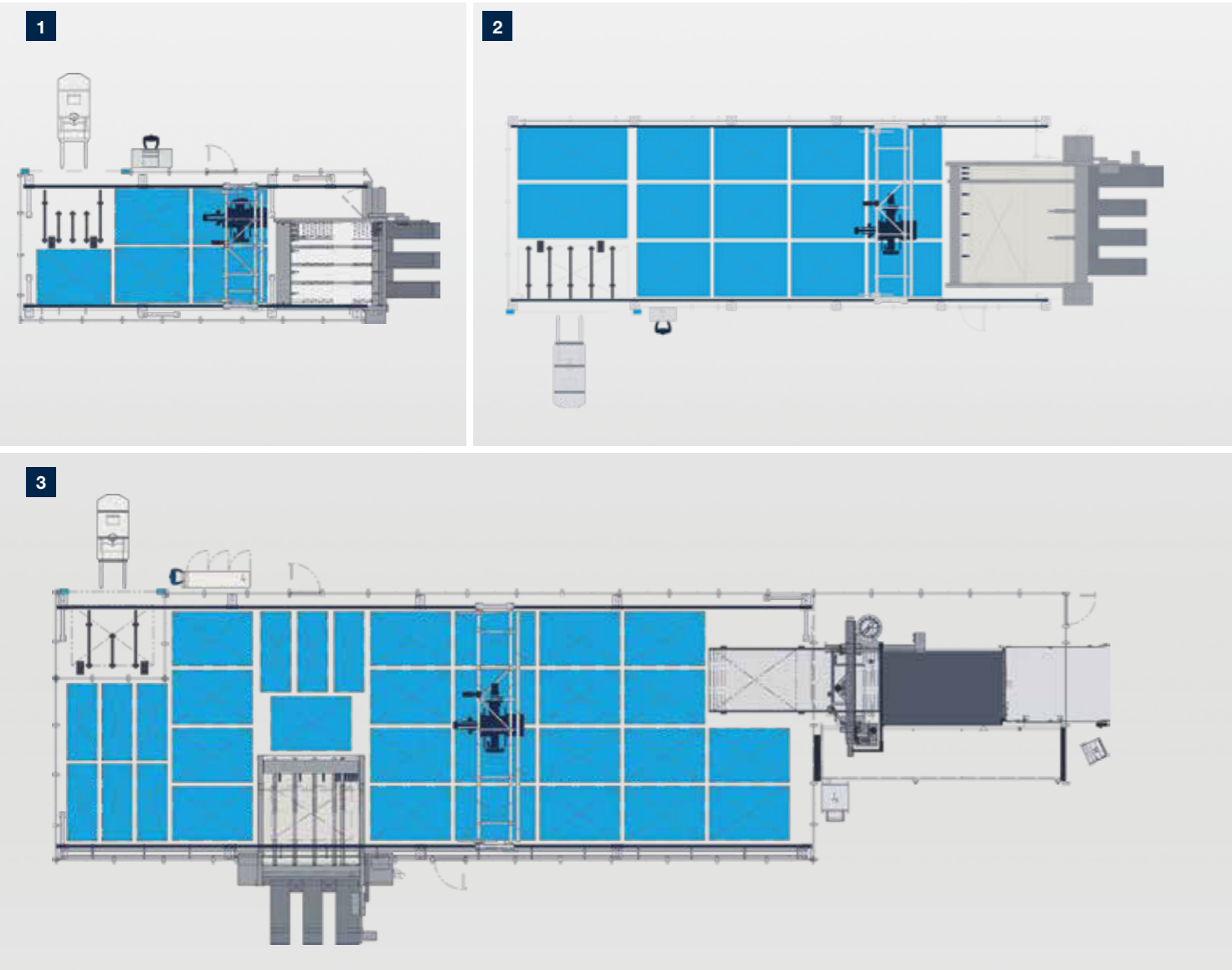

1 Storage and saw with 5 stacking positions

Users include those working in traditional joinery

2 Storage and saw with 14 stacking positions

Users include fitters

3 Storage with saw and CNC processing with more than 20 stacking positions

Users include those working in trade fair and shop construction, suppliers

module45 – giving your saw the scope to produce bevel cuts

With module45, you can now produce all cuts, including bevels, on one and the same saw. Work efficiently and flexibly without changing station, at infinitely variable angles ranging from 0 to 46 degrees.



The technology

- module45 consists of a stationary saw carriage with a tilting saw blade that can be adjusted infinitely variably to angles of 0 to 46 degrees
- When viewed from the front, the unit is integrated into the air cushion table on the far left
- The table plate can be opened, allowing easy access to the saw carriage for changing saw blades
- Other features include dedicated systems for contact pressure and dust extraction, plus a fold-down right-angled fence for maximum handling flexibility at the front of the saw

Incorporate bevels into cutting patterns

Now you can also incorporate bevel cuts into your cutting patterns: either using the Cut Rite optimization software when preparing work in the office, or when inputting the patterns directly in CADmatic. Parts to be processed with module45 are then cut (oversize) and the operator only needs to set the angle of the bevel on module45 and start the cut.

The benefits of module45

- Easy one-man operation
- Greater ergonomic and safety benefits than a circular saw
- Less waste and higher quality thanks to less transport damage as the material remains on the one machine
- Retrofit possible at any time on request

[MORE AT HOMAG.COM](https://www.homag.com)



module45

Power Concept Classic – for even more performance and material throughput

At the heart of this technology is a clamp that can be moved separately. Using this clamp, two strips with different cross cuts can be cut to length together.



Power Concept Classic for the SAWTEQ S-200 (without lifting table) delivers up to 30% more output

- An additional clamp operates independently on the program fence and moves in front of the program fence if necessary
- An algorithm adapted to the Power Concept Classic sorts the strips directly at the saw. This is based on existing optimization data for the shortest machining times
- Good to know: if you choose Power Concept Classic, you will automatically receive the first air cushion table in a wider version. In addition, the saw is equipped with another start-stop key on the second air cushion table.



Power Concept Advanced for the SAWTEQ S-210 with lifting table delivers up to 40% more output

- An additional clamp that operates independently
- Clamps on the program fence that can be raised out of the overlapping work area as needed
- An algorithm adapted to the Power Concept Advanced sorts the strips directly at the saw. This is based on existing optimization data for the shortest machining times.

Features with Power Concept Advanced:

- Protective fence instead of protective guard
- For technical reasons, saw blade projection is automatically limited to 80 mm.

POWER CONCEPT



Lower costs per cut



Significantly improved material flow



High material throughput to easily handle peaks in production

Our recommendation: Power Concept in combination with IntelliGuide Classic

The innovative assistance system supports the machine operator with the help of LED light signals at the cutting line in the safe, simple and fast processing of the increased material throughput.

Cuts what is put on the table

The SAWTEQ S-200 / S-210 has an appetite for almost anything. Intelligent optional features ensure it can tackle practically all the tasks and materials required in the cutting process.



Start/stop bar on first Air cushion table

- For convenient program start independent of the control panel
- The start/stop bar is particularly suitable for handling large panels or strips
- Replaces the start/stop button at the end of the first air cushion table



Movable air cushion table

The air cushion table is easily moved along linear guides and offers you a mobile work surface and storage area. It allows you to move small panels, large panels or books of panels more ergonomically and with less risk of damage.

Wider table elements (not shown)

Air cushion tables are optionally available in a width of 800 mm instead of 650 mm. Just one, two, three or all four – whatever is best for your production.



The perfect postforming cut

- Ensures perfect cuts on soft-formed and post-formed parts
- Maximum saw blade projection: 44 mm

MORE AT HOMAG.COM



Postforming



Air cushion tables

Additional clamps

For a better grip. So that your saw can securely clamp even big, thin or smooth panels.

More power for the main saw

The SAWTEQ S-200 / S-210 can be equipped with a more powerful main saw motor. You can increase the power from 7.5 kW to 9.2 kW, 11 kW or even 18 kW.

Gentle material handling

Additional rollers on the edge of the air cushion table ensure particularly gentle positioning of material and greater operator comfort.

Higher speed and throughput

- Saw carriage speed of up to 120 m/min instead of the standard 80 m/min
- Higher saw blade projection of 80 or even 95 mm instead of 60 mm



Greater visibility while maintaining safety (for single saws without lifting table only)

While saws with lifting table come as standard with an all-round protective fence, saws without lifting table have a protective guard around the rear machine table. The sides of this protective guard are made up of individual elements which can be equipped with windows if desired – one is already included as standard. Further windows can be added as needed. This ensures greater visibility while maintaining safety levels.

Extra tools for demanding materials and cuts

Exceptional materials require exceptional technical solutions. These are available in abundance for the SAWTEQ S-210 – for thin panels, for example.

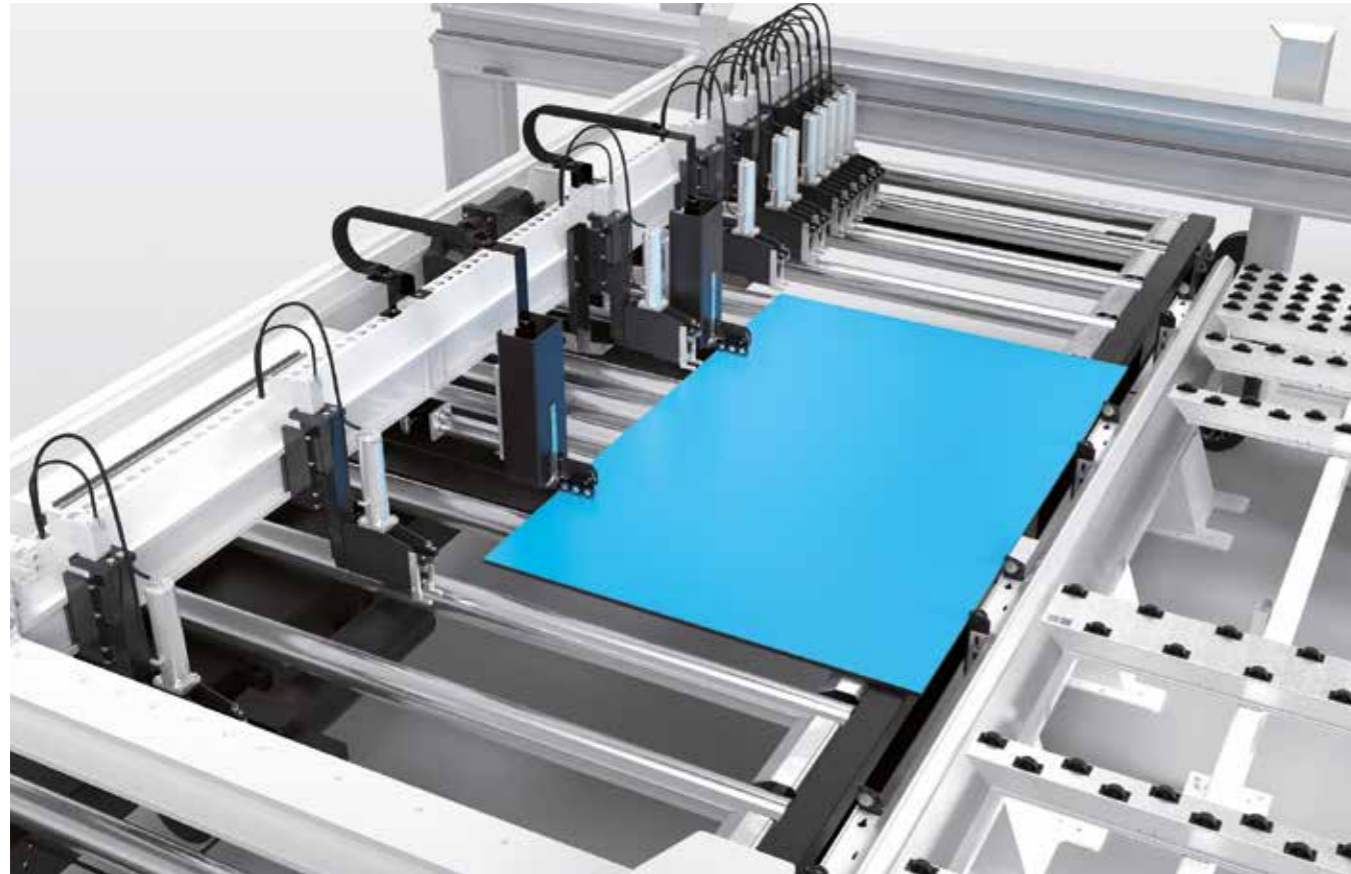

Micro feed for thin panels (for saws with lifting table only)

The micro feed option allows thin panels from 6 mm upward to be pushed onto the rear machine table (provided that their properties meet HOMAG specifications). Book height is measured by a non-contact, electromagnetic measuring system which is completely maintenance-free.

Extra impetus for feeding (for saws with lifting table only)

The automatically driven roller conveyor integrated into the lifting table and additional roller conveyors on the side ensure fast stack changeover.

MORE AT HOMAG.COM



Micro feed



Cut-out and stress elimination cut

Stress in the material is released when it is cut and can affect the quality of dimensions and cuts. The stress elimination cut provides a solution here. Systematic preliminary cuts can be defined during optimization and release the tension in the material. The additional cut-out feature allows you to produce both cut-outs and intermittent grooves in panels, as required for kitchen sinks or doors, for example.



Grooving

This option saves you an entire work step in post-processing. This is because your saw will also groove the panel material. There's more: thanks to the motorized groove adjustment, the groove depth can easily be adjusted to individual requirements directly on the control panel.

MORE AT HOMAG.COM



Grooving



Manual trim stops

With these, your saw can also master material with overhanging laminates or veneers. The trim stops are integrated into the clamps and are simply flipped forward when required.

- Gentle handling of sensitive materials with overhanging covering layers
- Precise positioning

MORE AT HOMAG.COM



Cut-out function

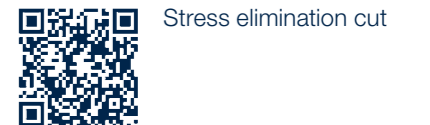

Stress elimination cut



Pneumatically operated trim stops

The trim stops are attached to the clamps and are activated as needed by the CADmatic machine control unit.

- Gentle handling of sensitive materials with overhanging covering layers
- Precise positioning

dustEx: making dust a thing of the past!

The more dust and chips that can be taken away by the dust extraction system, the better. After all, dust and chips can cause scratches on sensitive surfaces.



[MORE AT HOMAG.COM](https://www.homag.com)



Patented dustEx technology

dustEx guides dust and chips on a direct route toward the dust extraction system. How does it work? Using combination air jets and an optimized extraction geometry at the right-angled fence.

Reliable labeling and identification

To ensure that your processes also continue to flow smoothly after the saw, HOMAG offers you needs-based labeling solutions. For fast labeling and reliable identification at all downstream stations.



Classic label printer

The Classic label printer provides an introduction to part identification. Provide all process-relevant information for the subsequent work steps.



Advanced label printer for superb results

The label printer from HOMAG allows you to print customized labels directly at the saw and design them to include bar codes, text and graphics if required. If you also use our Cut Rite optimization software, the material goes directly to the next process step with printed instructions. In this way, you can integrate the saw perfectly into your production flow.

[MORE AT HOMAG.COM](https://www.homag.com)



TECHNICAL DATA*		
Model	SAWTEQ S-200	SAWTEQ S-210 with lifting table
Saw blade projection (mm)	65 (optional: 80 or 95)	65 (optional: 80 or 95)
Cutting length (mm)	3200/3800/4300	3200/3800/4300
Lifting table width (mm)		2,200
Program fence speed (m/min)	up to 80 **	up to 80 **
Saw carriage speed (m/min)	up to 80 (optional: 120)	up to 80 (optional: 120)
Main saw motor (kW)	7.5 (optional: 9.2, 11 or 18)	7.5 (optional: 9.2, 11 or 18)
Scoring saw motor (kW)	1.1 (optional: 1.5)	1.1 (optional: 1.5)
Average total air requirement (NI/min)	150 (200 at 95 mm saw blade projection)	150 (200 at 95 mm saw blade projection)
Required compressed air supply (bar)	6	6
Dust extraction system (m ³ /h)	3300 (26 m/sec)	3300 (26 m/sec)
Processing height (mm)	920	920
Air cushion tables (mm)	3/3/4 x 1800	3/3/4 x 1800
Monitor	24" TFT flatscreen display	24" TFT flatscreen display

* Values relate to the standard features

** Forwards 25 m/min

*** Dim. A: incl. 40 mm for extraction connection, dim. C: standard program fence width

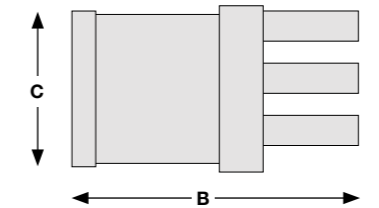

MACHINE DIMENSIONS***			
SAWTEQ S-200	A (mm)	B (mm)	C (mm)
S-200/32/32	5,347	6,037	3,587
S-200/38/32	5,907	6,037	4,147
S-200/38/38	5,907	6,637	4,147
S-200/43/32	6,497	6,037	4,737
S-200/43/38	6,497	6,637	4,737
S-200/43/43	6,497	7,187	4,737

MACHINE DIMENSIONS***			
SAWTEQ S-210 with lifting table	A (mm)	B (mm)	C (mm)
S-210/32/22	5,307	9,482	3,636
S-210/38/22	5,867	9,482	4,196
S-210/43/22	6,457	9,482	4,786

LIFE CYCLE SERVICES

Improved performance, more efficient processes, faster help, assurance of availability and smarter working

TEAM & COVERAGE

Largest global service network in the industry with over 1,350 personnel.

INSTALLATION & COMMISSIONING

For a smooth start, we only let proven experts manage your setup.

OPERATION & CONTROL

After teaching your personnel the intuitive control system, our clever apps help to make the operator's life much easier.

MAINTENANCE & SERVICING

To keep things running, we're happy to take a preventative approach. You decide how often and how intensively you want the support to be. As we all know, prevention is better than the cure.

eSHOP & ONLINE ADVANTAGE

A few clicks and it's fixed. Receive exclusive advantages by ordering spare parts online, depending on market availability. shop.homag.com

HOTLINE & READINESS

When there's an emergency, we're here. Direct by phone, digitally via app or video, or with on-site support. We are close to you with over 90 regional service organizations worldwide. With more than 35,000 spare parts immediately available, we can deliver 85% of your orders fast.

TRAINING & EDUCATION

With classroom, live online or eLearning training, we offer flexible options to help you get knowledge. We conduct over 4,000 customer training courses every year, and we even have our own training centers in 19 countries

MODERNIZATION & IMPROVEMENT

Our modernization program is tailored to your machines and processes. We can evaluate your data and situation and advise you on the next step.

ANALYSIS & SUSTAINABILITY

On request, we analyze all your processes with proven tools and procedures (LeanSixSigma). We have a large, certified team of experts for this purpose.

FINANCING & CONSULTING

We offer you tailor-made financing concepts worldwide. With more than 60 years of experience and a close partner network of prominent banks and insurance companies to help us to find the right solution for you, we're always transparent and reliable in processing.

Fast support:
94% resolution rate
via our hotline

Close to you:
1,350 service experts worldwide

We get things moving:
Over 1,000 worldwide spare parts
shipments each day

No one else has that:
Electronic documentation on over
150,000 machines, available in 28
languages



HOMAG Group AG

info@homag.com
www.homag.com

YOUR SOLUTION