

DRILLTEQ H-230

6-sided processing center
CE version



Building living spaces.

From furniture to homes: The future is built with wood.

Together, HOMAG, WEINMANN, SYSTEM TM and KALLESOE provide comprehensive production solutions for manufacturers of optimized timber, engineered wood, timber construction, interior fittings, furniture and more. With over 500 years of combined experience in machinery engineering, automation systems, and software technology, our focus is on building strong partnerships that enhance your productivity, precision, and profitability.

This is how we are Building living spaces. Together, with you.

HOMAG – YOUR SOLUTION



High-precision CNC solutions.

Dimensional accuracy, repeat accuracy, fits – precision is the top priority in CNC machining. That's why we offer superior technology and individual equipment for the high-precision production of furniture, interior fittings and construction elements.

To ensure that your individual furniture transforms rooms into living spaces in the future, too.

Building living spaces.

Building precision.

**A millimeter
off is a world
apart.**





DRILLTEQ H-230

The 6-side drilling series DRILLTEQ H-230 impress with speed and precision – in workpiece handling as well as in machining. Every drilling and processing operation is set with repeat accuracy. The workpiece surfaces are protected despite fast processing speeds.

With our 6-sided drilling series, we provide the perfect solution for your wishes and requirements.

www.homag.com

CONTENTS

- 06 6-sides-processing technology
- 08 Single-channel operation
- 10 Drilling technology
- 12 Tool change system
- 13 HSK interface
- 14 Comprehensive safety concept
- 16 powerTouch
- 18 Software
- 20 Life Cycle Services
- 22 Application examples
- 23 Technical data

DRILLTEQ H-230

The perfect start in the 6-sides-processing technology

Operation with one working field for precise drilling process at panels in all 6 sides. The workpieces are optimally positioned by CNC-controlled clamps. High-speed drilling spindles and routers are available. With optional tool change spindle, more application can be realized on this machine in order for high-level flexibility.



FULL PANEL PROCESSING...

6 sided-processing along 1 working field

EVERYTHING UNDER CONTROL...

2 CNC-controlled clamping devices ensure permanently firm and precise positioning of the workpieces – regardless of the speed

EASY HANDLING...

Even workpiece dimensions of Length 250-3,000 and width 60(40)-1,250 mm are easy to handle

PRECISE IN DEPTH...

The spindle clamping technology ensures an always accurate drilling depth for all drilling

CONSTANTLY AT TOP LEVEL...

The closed straight guiding system is protected against dust and dirt and thus very durable

MORE PROCESSING POSSIBILITIES...

Optional top electric spindles with automatic tool changer make processing more possibilities.



CNC-controlled clamping system

- Quick and precise – no setting times
- Workpiece thickness up to 40 mm



High-Speed Processing Unit | Top

- One Drilling Block V13, H6X, H6Y, optional routing spindle
- Two Drilling Blocks V13, H6X, H6Y, optional routing spindle
- High-Speed grooving saw unit in X direction

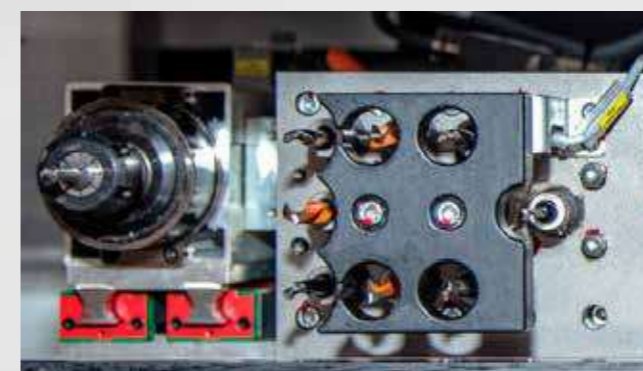

High-Speed Processing spindle and drilling gear | Bottom

- One Drilling Block V8, processing spindle 3.5 kW



Push-holder device

- Additional support on the side of the workpiece
- Ensuring processing accuracy despite movement and position changes of the clamps

DRILLTEQ H-230

Configurations for the single-channel operation

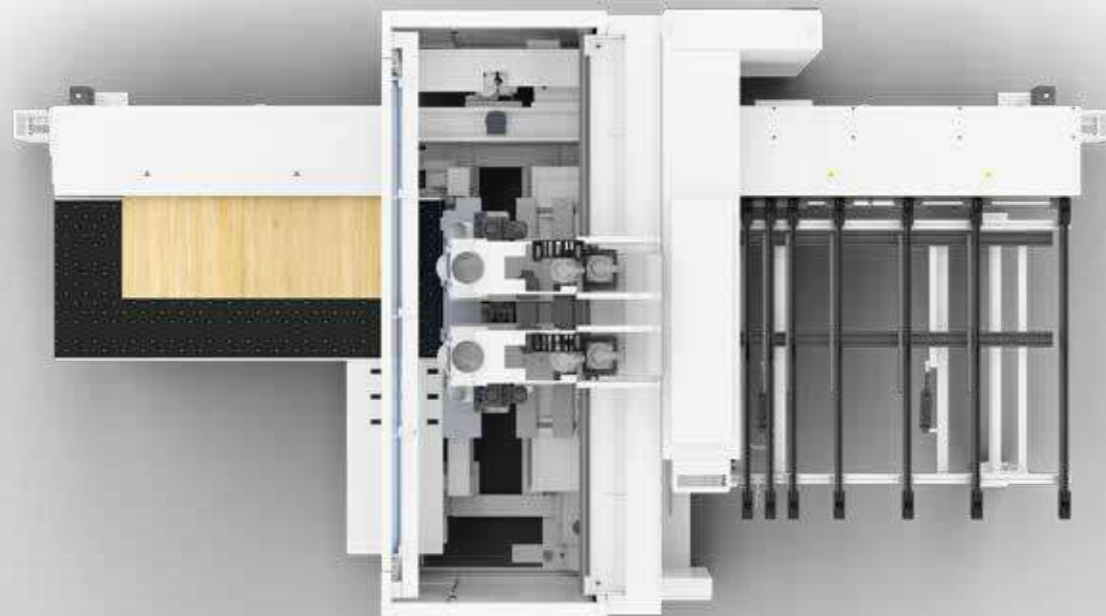

Classic Package – Infeed and outfeed by labour

- Processing can be launched by scanning the bar code
- High flexibility due to manual operation
- In-feed with air-cushion table and outfeed with cross belt

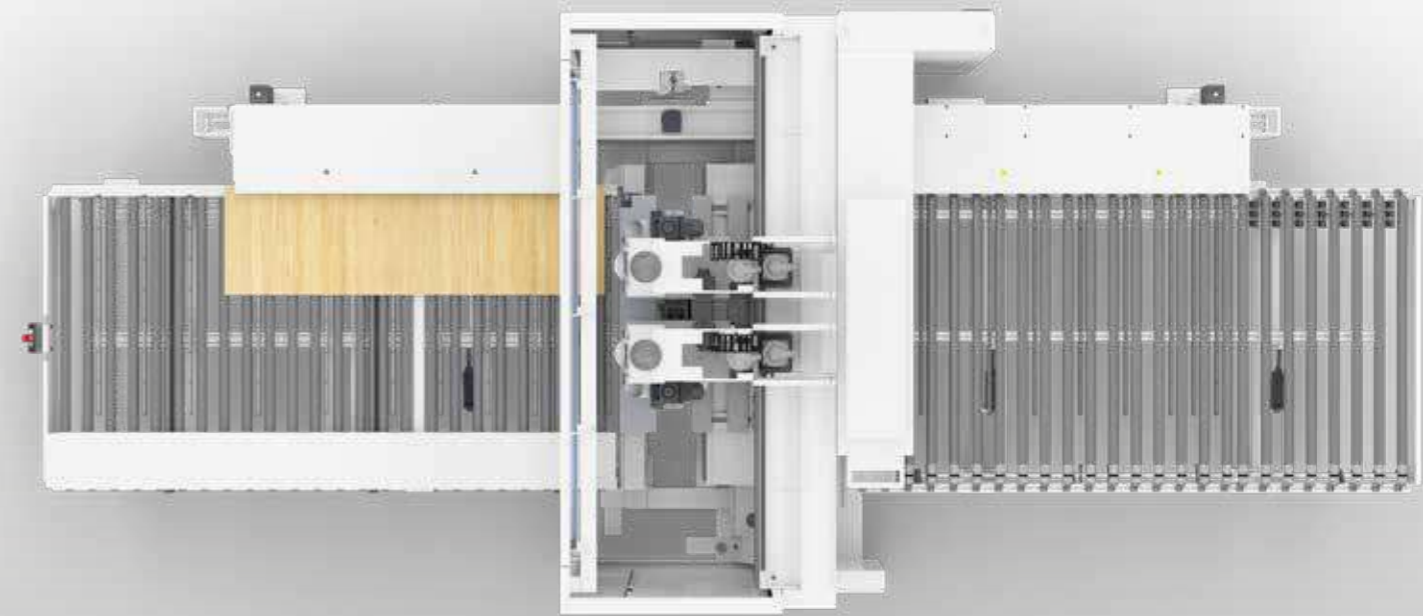

Premium Package – Automate your processes

- Each workpiece is concretely identified for further part flow by means of barcode
- Well suited for medium to high batch processing
- In-feed and out-feed with roller conveyors

HOMAG drilling technology

The best of the best

High-speed drilling technology, clamping of the spindle for tools. Precise drilling, fast cycles, maintenance-free and durable design.

Additional optional attachment units expand the machine's range of applications.

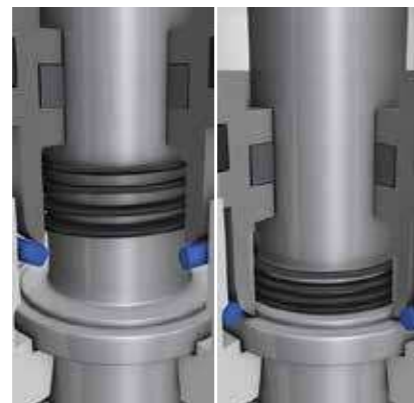
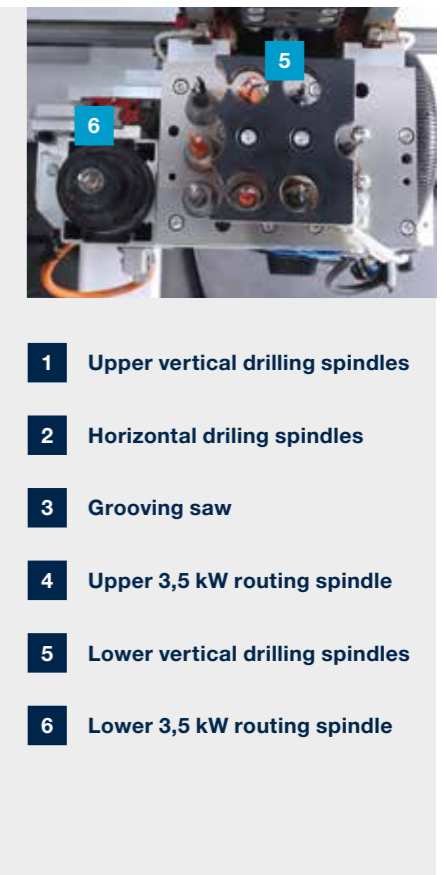
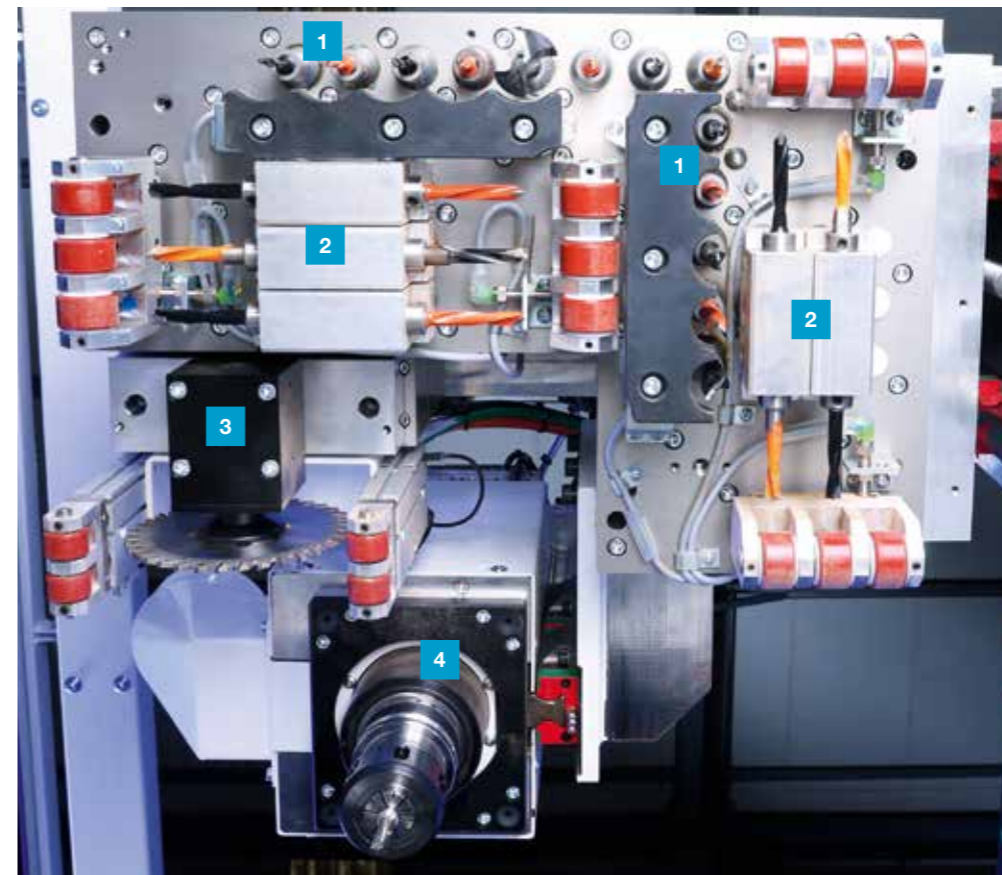
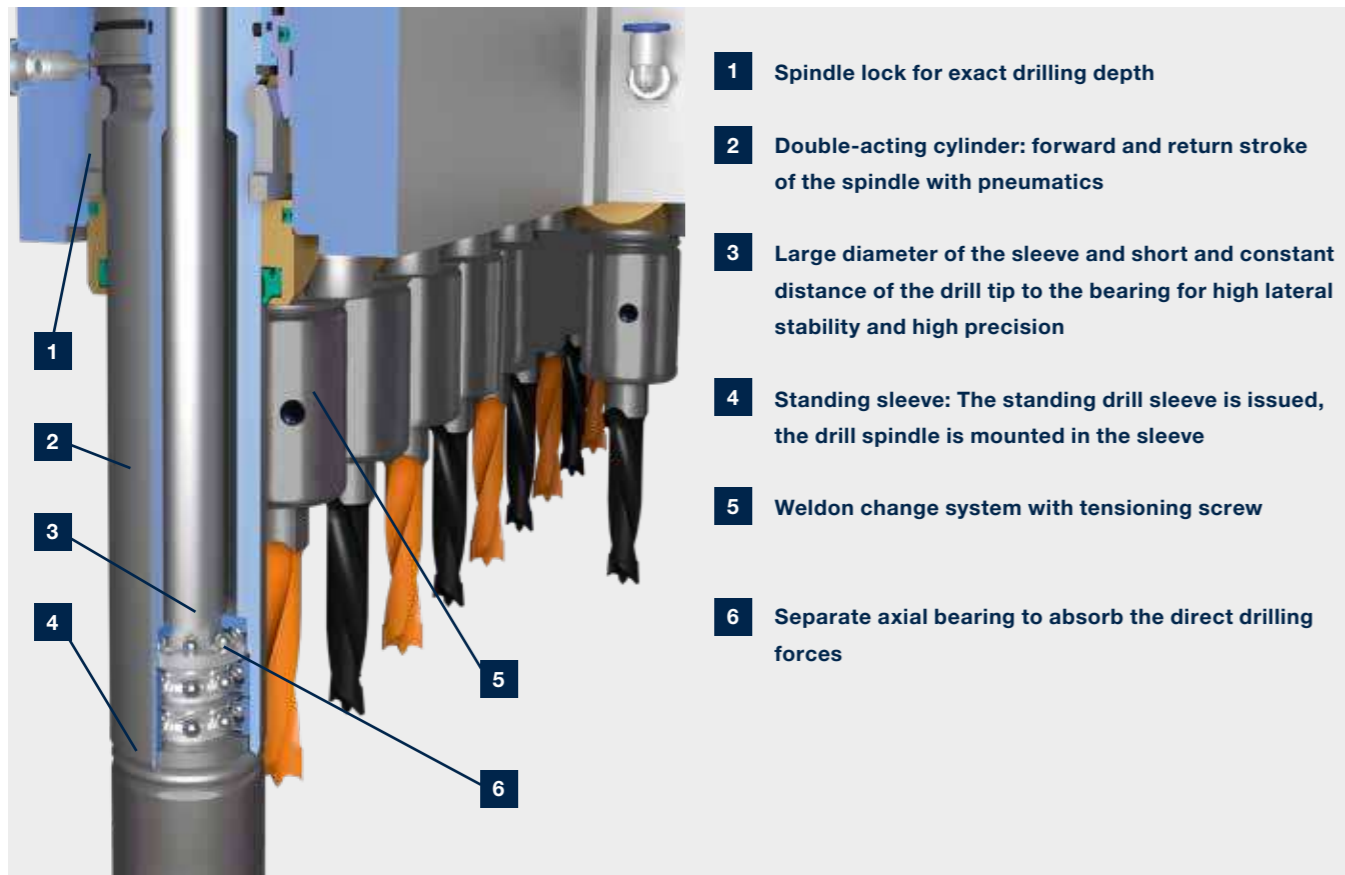

Automatic spindle lock

- System for an always exact drilling depth with different materials.
- With speeds from 1500-7500 1/min. for high feed rates or short drilling cycles

Weldon change system
For a drill bit change with tools.



Split head

- For simultaneous processing of e.g. rows of holes or cabinet sides

Tool change system

The right selection for your needs

IN PERFECTION! The various tools allow you an individual selection for your requirements.

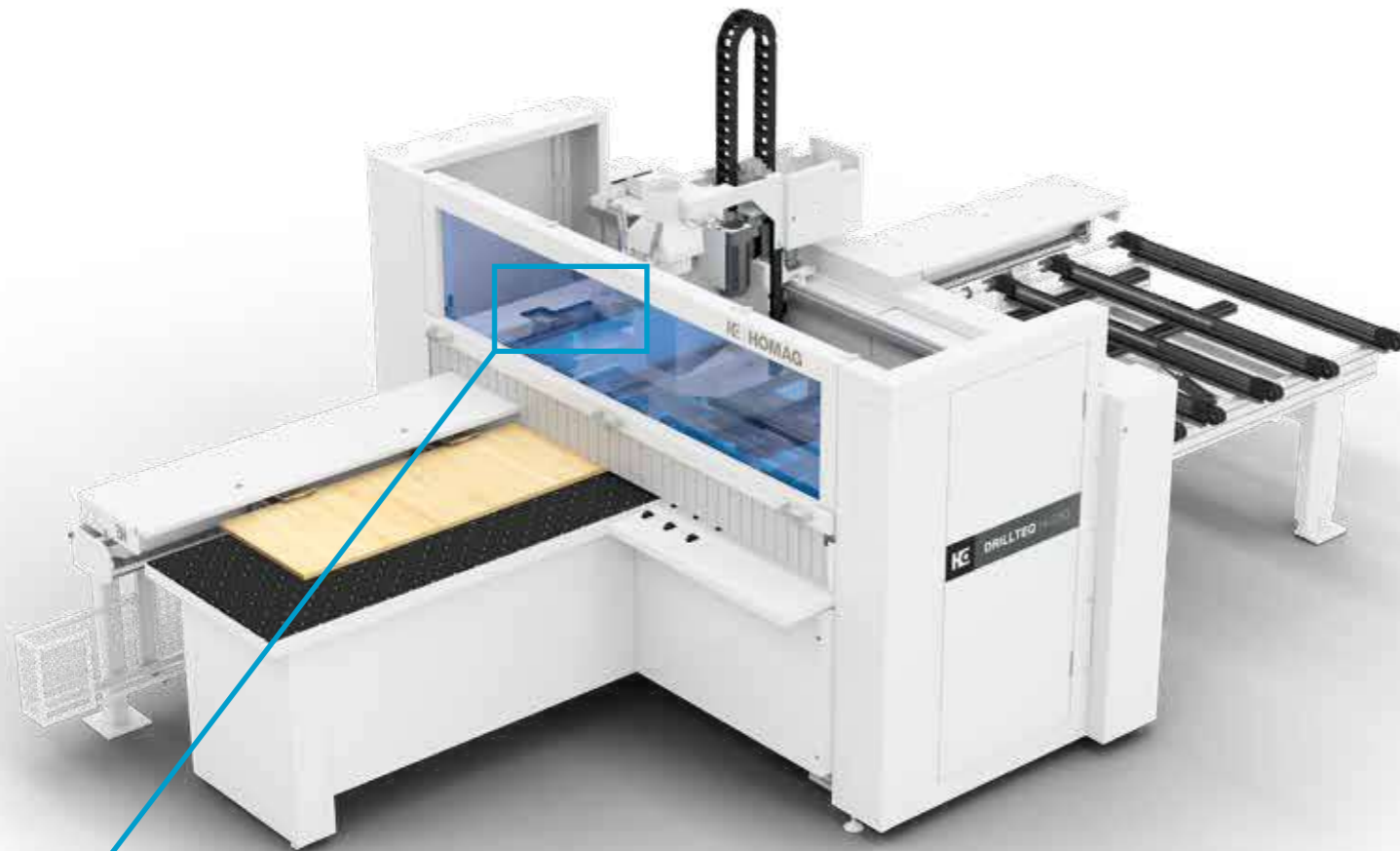

Optional equipment with automatic tool change system provides you with more processing possibilities. Available for 6-side drilling series DRILLTEQ H-230.

Tool Change System

- Spindle with HSK F63
- 4-fold linear tool changer
- Optionally mounted at the side of machine
- Convenient and automatic exchange of tools from sides
- Tool length control: tool length is queried and compared with the integrated tool database

HSK tool chuck

Holds securely what belongs together

HOMAG relies on the HSK interface between the tool and the work spindle. At this important position, the tool holder must be able to guarantee a tight fit, but also a quick tool change and precision in the manufacture of the workpiece. The HSK holder does this reliably.

Added value compared to ISO steep taper shank

- The clamping force acting on the flange of an HSK shank is twice as high as on an ISO steep taper shank. An HSK shank is therefore much more resistant to pull-out forces. This means that a tool can be operated at higher speeds.
- Thanks to the additional clamping force, the radial rigidity of HSK tool holders is up to five times higher than that of ISO tool holders.
- Another HSK improvement over ISO steep taper shanks is the tool change capability. Due to the short length of the HSK taper and the lower weight of the hollow shank, tool changes can be carried out more quickly than with conventional tool holders.

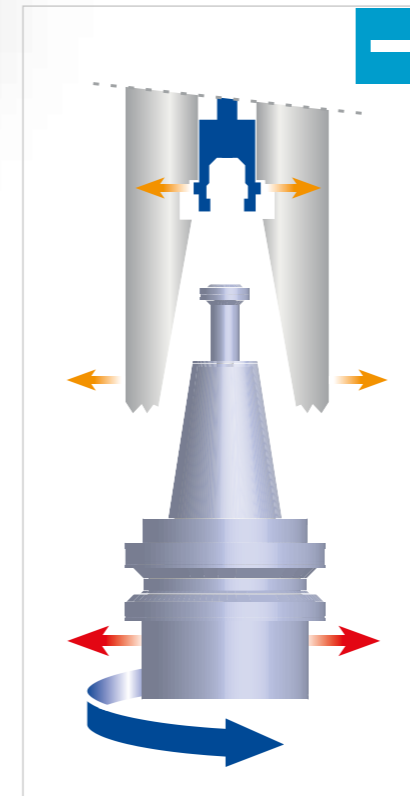

ISO steep taper shank

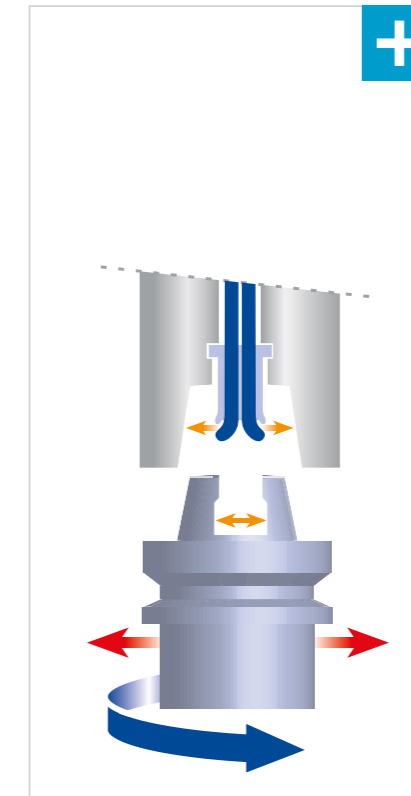

HSK shank



Advantages of HSK at a glance

- More resistant to bending loads
- Radial rigidity, deeper cuts and higher feed rates for milling and drilling operations, improving processing accuracy and surface quality
- Quick tool change thanks to short HSK taper and no retaining catch for clamping the shank



Comprehensive safety concept

Safety first – because operator's safety is our highest priority!

The DRILLTEQ H-230 has a comprehensive safety concept. The safety fence protects from 3 sides. Supplemented by a light barrier, this prevents intrusion into the work area. The safety guard above the moving collets closes off the machining area to ensure the safety of the operator during machining.

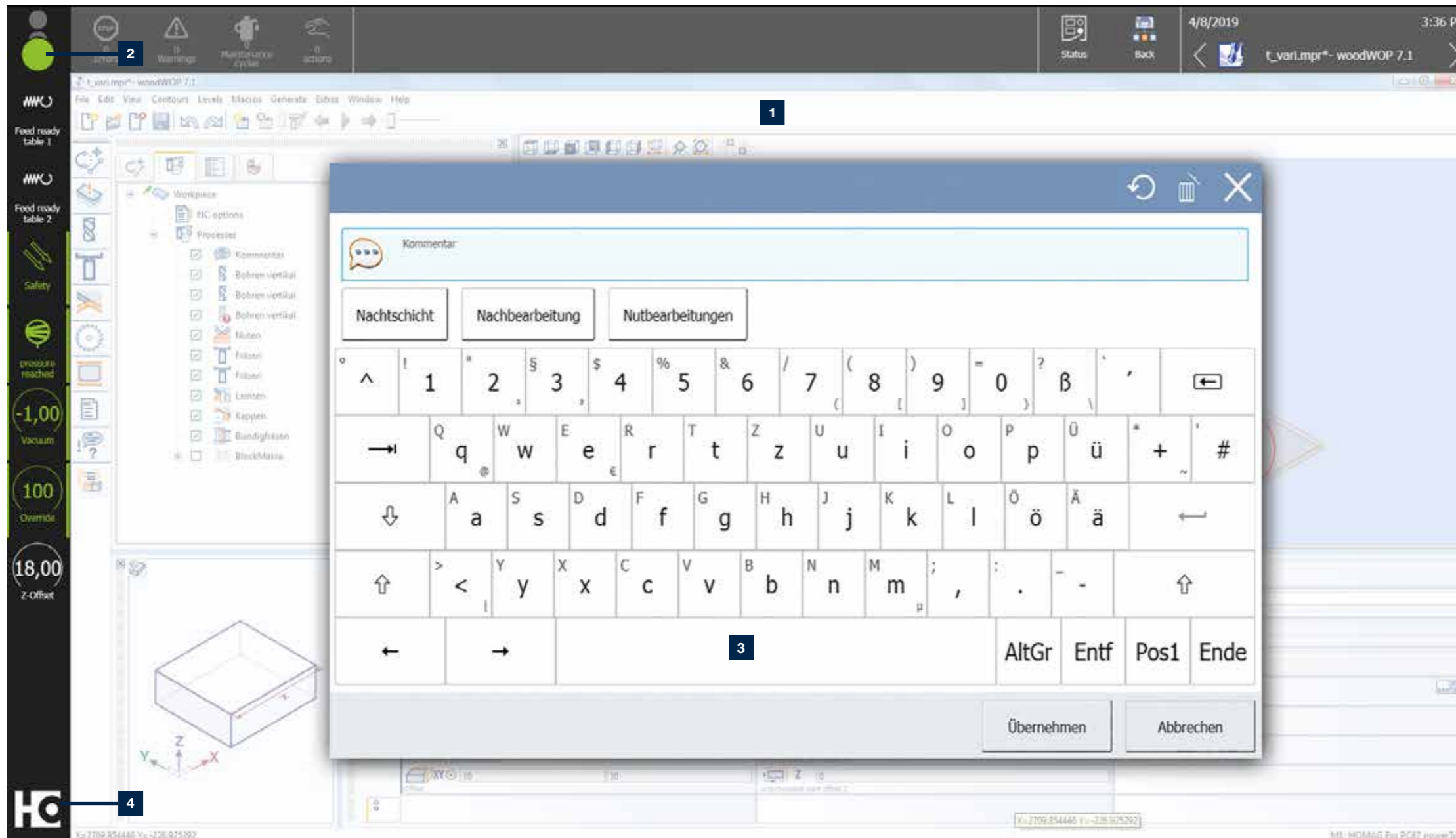

The next generation of powerTouch: **powerTouch2**

Faster, more comfortable, clearer: Enjoy the benefits of our further improved powerTouch user interface. We have optimized our standardized operating concept and further adapted it to our customers' requirements. Controlling your HOMAG machines is now even faster and more intuitive. The new, modern design has a clear structure. The innovative touch operation allows you to achieve the desired result easily and comfortably.

With the new powerTouch generation, you can enter information at your machine even more quickly. Compared to the previous version, you can achieve a time saving of up to 30%. This is possible thanks to new features, such as automatic word completion, a pop-up keyboard that can be kept open and Windows-like functions, such as the selection of common actions directly via the start button.

1 The powerTouch2 screen is clearly structured. You can see all the important information at a glance, but you still have all the details.

2 We have also improved the traffic light dialog further. You can now directly influence the machine's production readiness by selecting actions via the traffic light icon.

3 A functional pop-up keyboard that can be kept open, including automatic word completion for faster entries (when you enter the first letters, frequently used applications are proposed and you can select them directly).

4 Enhanced "Start" menu with additional information displayed (e.g. an indication of how many messages are currently pending or status bars that show the progress of the application) and direct access to actions (e.g. confirmation of actions without having to jump to the application).

Our successful powerTouch philosophy – **standardized, simple, ergonomic, evolutionary** – consistently further developed



THE HIGHLIGHTS AT A GLANCE:

- Direct and efficient operation, up to 30% faster
- Clearer and more informative thanks to additional information and live illustrations instead of program icons
- New applications for operating and controlling machines and systems (e.g. NCCenter in the PC87 control system on CNC machines or woodCommander 4 on throughfeed machines)
- Fresh, attractive design, based on the new HOMAG machine design

Software All inclusive

WITH THIS SOFTWARE PACKAGE YOU ARE "READY TO RACE". Thanks to 30 years of experience and multiple installations worldwide, with woodWOP you get one of the most established CNC programming systems in the world.

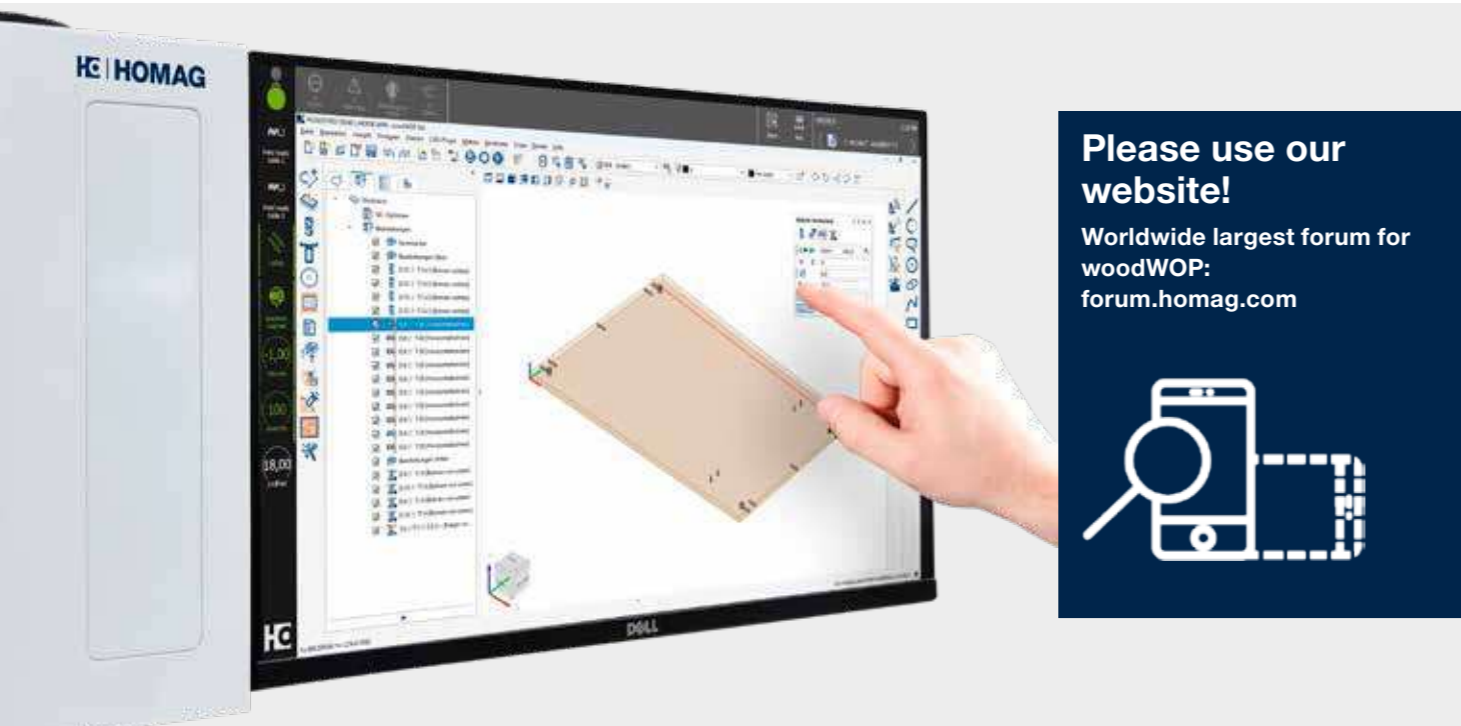

Please use our website!
Worldwide largest forum for woodWOP:
forum.homag.com

woodWOP | License for Machine

- Fast and intuitive operation through simple, direct navigation
- Arbitrary use of variables for flexible variant programming
- Quick creation of own components
- More programming security through 3D graphics of workpiece and machining operations

Software Option

ADDITIONAL SOFTWARE MODULES allow you to further optimize your processes.

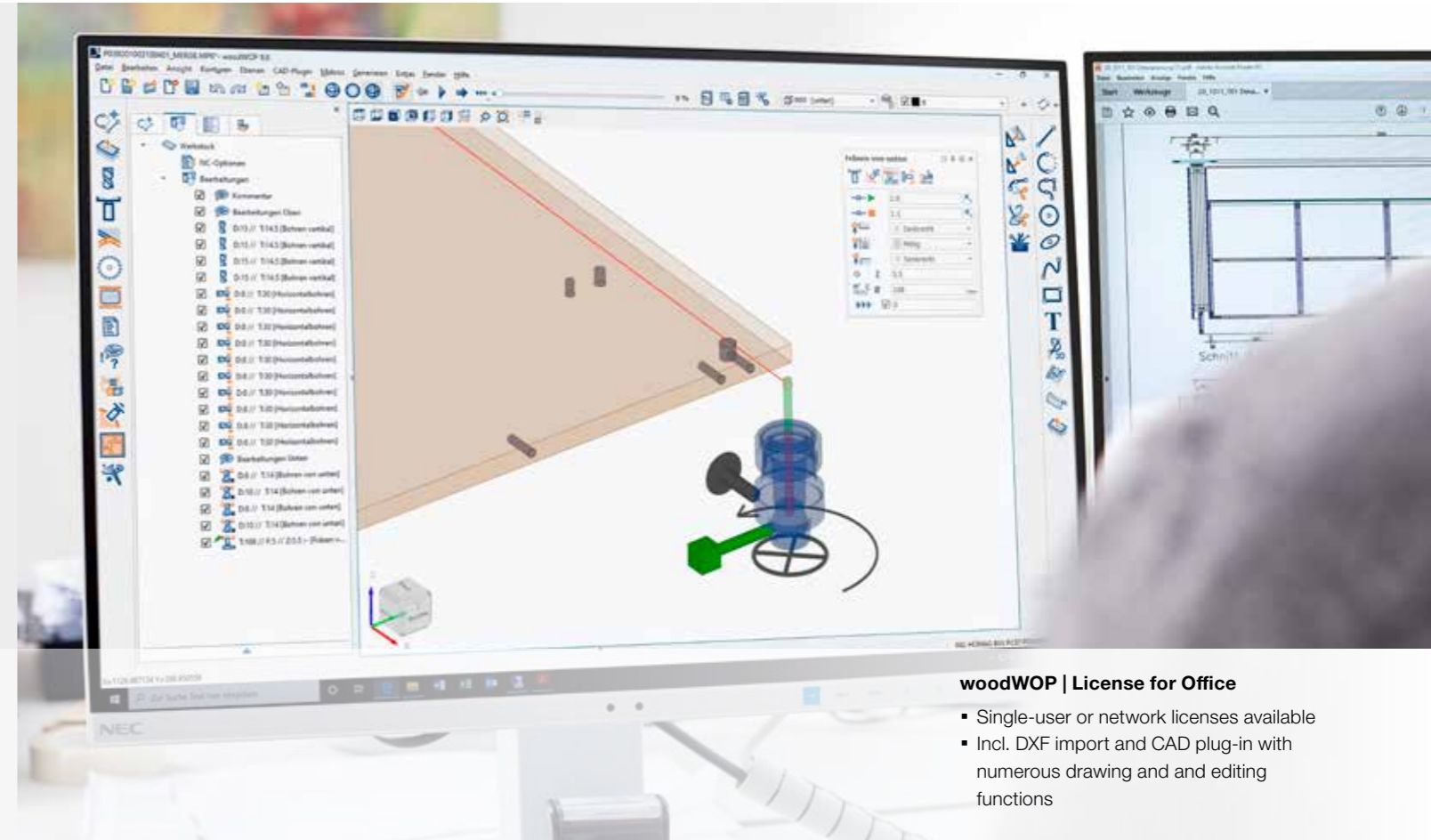

woodWOP | License for Office

- Single-user or network licenses available
- Incl. DXF import and CAD plug-in with numerous drawing and editing functions



Slot assignment

- Simple control of machine functions via soft keys
- Graphical assignment in 3D
- Rotation and mirroring of workpieces



woodWOP DXF Basic

- Interface for CAD data import
- Basis for the generation of woodWOP programs



MMR Basic

- Recording of quantities and actual operating times at the machine
- Integrated maintenance notes for optimal time- and quantity-based planning and execution of maintenance work

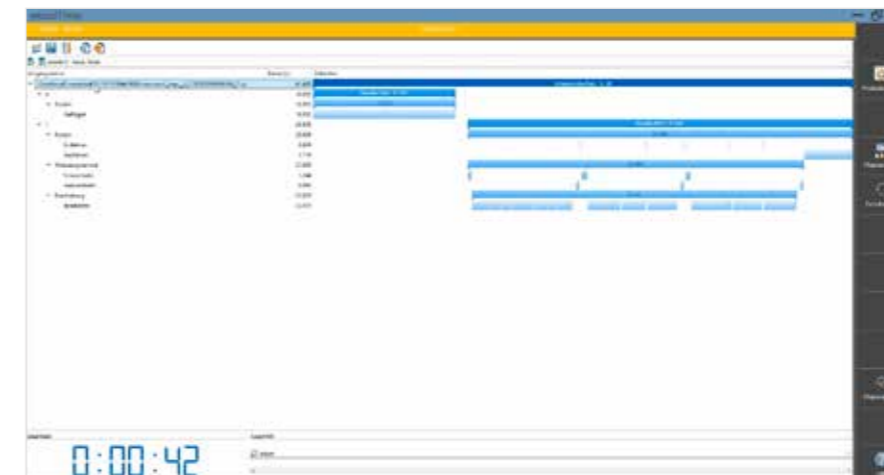

woodTime

- For time calculation and analysis of woodWOP programs
- Batch time calculation of production lists



Barcode reading system

- Fast call-up and allocation of machining programs via barcode scan
- Automatic and quick merge of two machining programs

LIFE CYCLE SERVICES

Improved performance, more efficient processes, faster help, assurance of availability and smarter working

TEAM & COVERAGE

Largest global service network in the industry with over 1,350 personnel.

INSTALLATION & COMMISSIONING

For a smooth start, we only let proven experts manage your setup.

OPERATION & CONTROL

After teaching your personnel the intuitive control system, our clever apps help to make the operator's life much easier.

MAINTENANCE & SERVICING

To keep things running, we're happy to take a preventative approach. You decide how often and how intensively you want the support to be. As we all know, prevention is better than the cure.

eSHOP & ONLINE ADVANTAGE

A few clicks and it's fixed. Receive exclusive advantages by ordering spare parts online, depending on market availability. shop.homag.com

HOTLINE & READINESS

When there's an emergency, we're here. Direct by phone, digitally via app or video, or with on-site support. We are close to you with over 90 regional service organizations worldwide. With more than 35,000 spare parts immediately available, we can deliver 85% of your orders fast.

TRAINING & EDUCATION

With classroom, live online or eLearning training, we offer flexible options to help you get knowledge. We conduct over 4,000 customer training courses every year, and we even have our own training centers in 19 countries

MODERNIZATION & IMPROVEMENT

Our modernization program is tailored to your machines and processes. We can evaluate your data and situation and advise you on the next step.

ANALYSIS & SUSTAINABILITY

On request, we analyze all your processes with proven tools and procedures (LeanSixSigma). We have a large, certified team of experts for this purpose.

FINANCING & CONSULTING

We offer you tailor-made financing concepts worldwide. With more than 60 years of experience and a close partner network of prominent banks and insurance companies to help us to find the right solution for you, we're always transparent and reliable in processing.

Fast support:

94% resolution rate via our hotline

Close to you:

1,350 service experts worldwide

We get things moving:

Over 1,000 worldwide spare parts shipments each day

No one else has that:

Electronic documentation on over 150,000 machines, available in 28 languages

Application examples

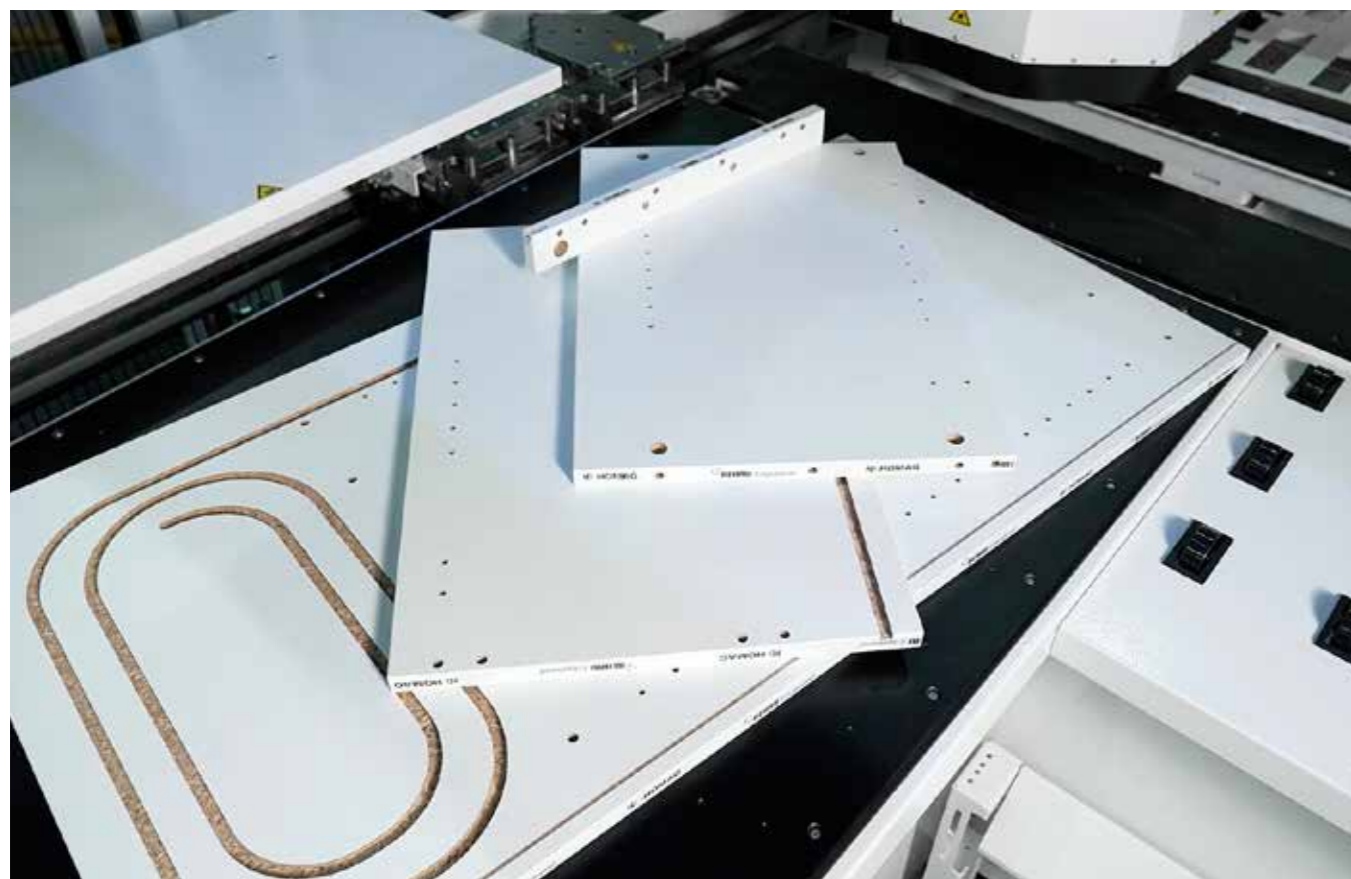

Technical data

TECHNICAL DATA		
Drilling Head TOP		
Vertical spindles	Qty	13 or 2 x 13
Vertical spindle clamping		Yes
Horizontal spindles in X+/X-	Qty	3X+/3X- or 2 x (3X+/3X-)
Horizontal spindles in Y+/Y-	Qty	2Y+/2Y- or 2 x (2Y+/2Y-)
Frequency controlled	RPM	1,250 – 7,500
Drilling Head Bottom		
Vertical spindles	Qty	8
Vertical spindle clamping		Yes
Frequency controlled	RPM	1,250 – 7,500
Machine		
Approx. machine weight	kg	5,000

	Classic	Premium
Workpiece dimension		
Length	mm 250 – 3,050	250 – 3,050
Width (narrow)	mm 40 – 800	–
Width	mm 40 – 1,250	60 – 1,250
Height	mm 8 – 40	8 – 40
Footprint (With Safety Fence)		
L	mm 10,350	7,700
W	mm 5,600	6,700
H	mm 2,550	2,550

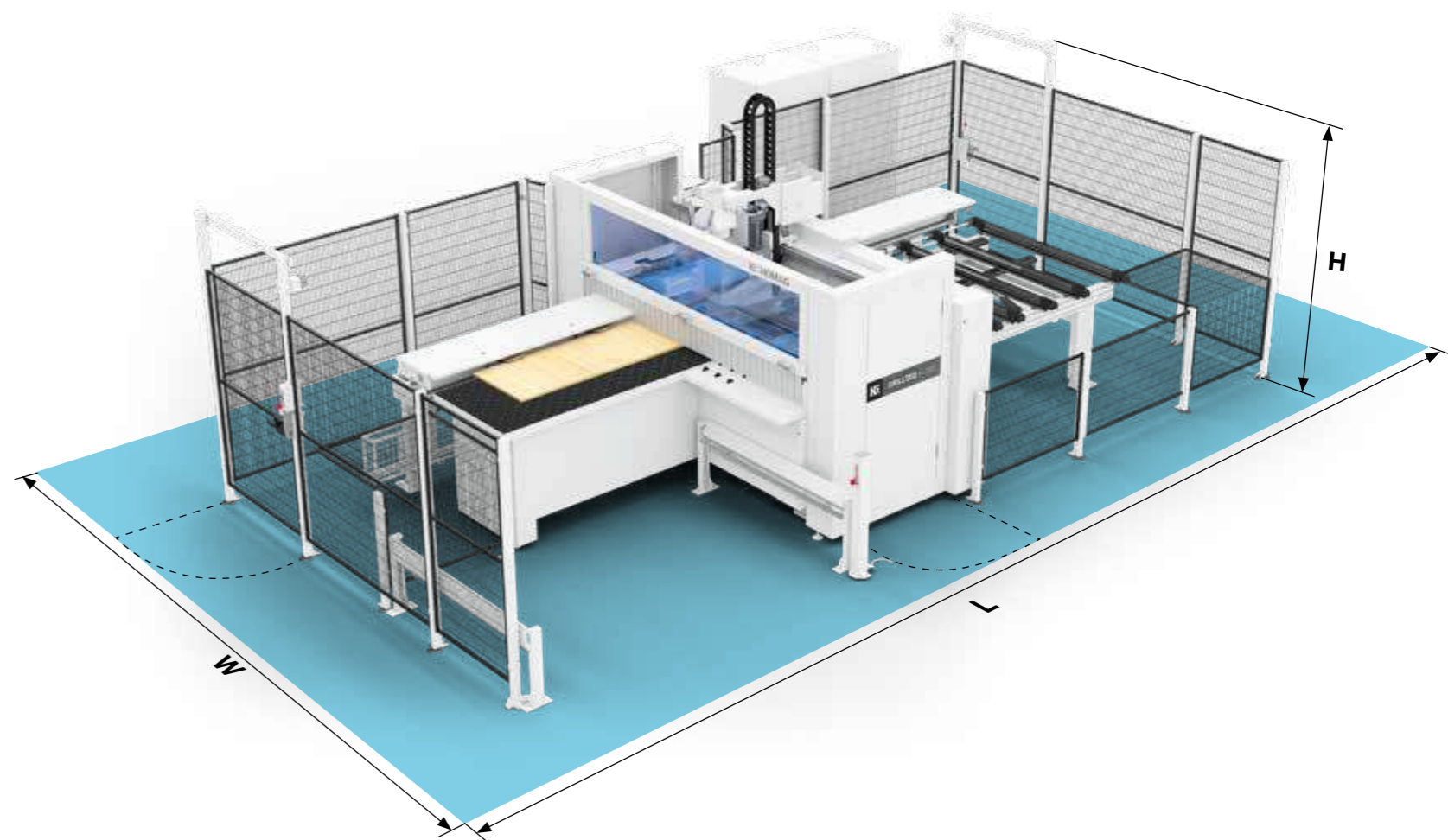

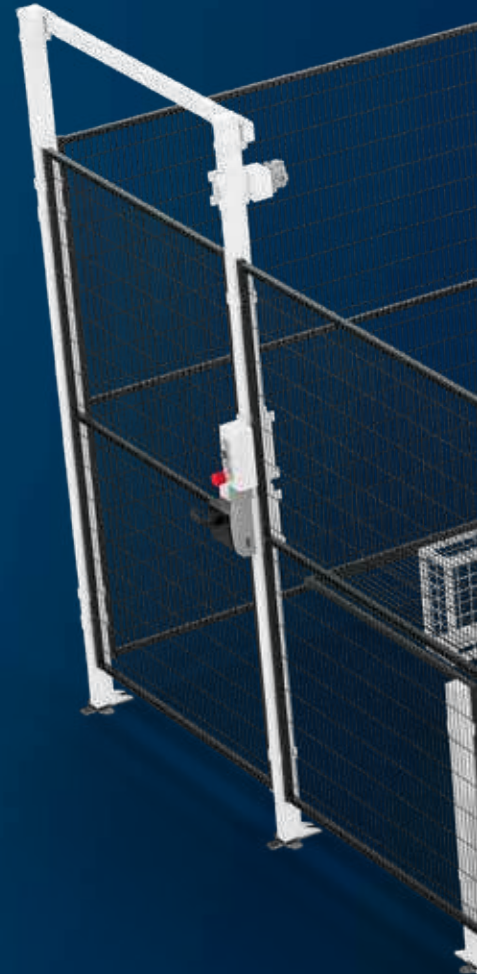

HOMAG Group AG

info@homag.com
www.homag.com

YOUR SOLUTION