

SBZ 150

Machining Centres

Description

- 5-axis profile machining centre
- Designed for economical and efficient machining of aluminium and thin-walled steel profiles
- All operations, such as routing, drilling, tapping, thread milling, notching and sawing, are performed while the profile bar is stationary to protect the profile surfaces
- 6-sided machining. From below with an angle head (option)
- Operator software with graphic 3D display of workpieces
- The magazine can be equipped with nine standard tools, five special tools (angle routing head and special cutters) and one saw blade
- Robust, low-wear direct drives on all axes allow rapid home positioning of the machining assembly
- Automatic clamp recognition and clamp positioning
- Two separate working zones enable machining in shuttle operation
- 5-axis controller for 3D machining, 15" colour display, USB ports, and network

- connection
- Windows operating system
 - eluCam

Machining lengths

SBZ 150 - 6.0 m

- Max. machining length with profile end machining, 5,900 mm
- Max. machining length without profile end machining, 6,220 mm

- SBZ 150 - 7.3 m

- Max. machining length with profile end machining, 7,200 mm
- Max. machining length without profile end machining, 7,520 mm

- SBZ 150 - 9.0 m

- Max. machining length with profile end machining, 8,900 mm
- Max. machining length without profile end machining, 9,220 mm

- SBZ 150 - 10.3 m

- Max. machining length with profile end machining, 10,200 mm
- Max. machining length without profile end machining, 10,520 mm

- SBZ 150 - 12.0 m

- Max. machining length with profile end machining, 11,900 mm
- Max. machining length without profile end machining, 12,220 mm

Options

- Shuttle operation for working on two sides
- Angle routing head for machining from below
- Automatic length measurement
- Chips conveyor belt
- Barcode scanner

- Label printer
- Clock system
- Tool holders
- Collet chuck
- Collets
- Saw blades
- Tools
- eluCad (office software package for optimized production management)

Technical data

- Traverse path X-axis, 6,500 mm, 7,800 mm, 9,500 mm, 10,800 mm, 12,500 mm
(additional lengths on request) Vmax. 70 m/min.
- Y-axis traverse path 1,000 mm, Vmax. 40 m/min.
- Z-axis traverse path 630 mm, Vmax. 40 m/min.
- A-axis pivoting angle: +/-110°, user programmable in 1/10° steps
- C-axis pivoting angle: +/-182°, user programmable in 1/10° steps
- Max. spindle speed 24,000 rpm
- Spindle power output 15 kW S1
- Cutting tool diameter 100 mm max.
- Disc milling cutter diameter of max. 100 mm
- Saw blade diameter up to 400 mm max.
- Tool holder HSK-63F
- Compressed air supply 7 bar
- Power supply 400 V, 3~, 50 Hz, 80 A
- Air consumption per minute, 200 l with spraying
-



Profile machining centre SBZ 150 eluCam

SBZ 150 + special accessories



Profile machining centre SBZ 150 eluCam

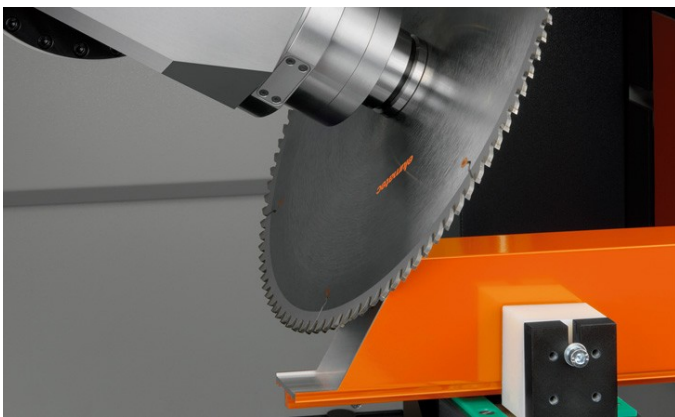

Profile machining centre SBZ 150 eluCam

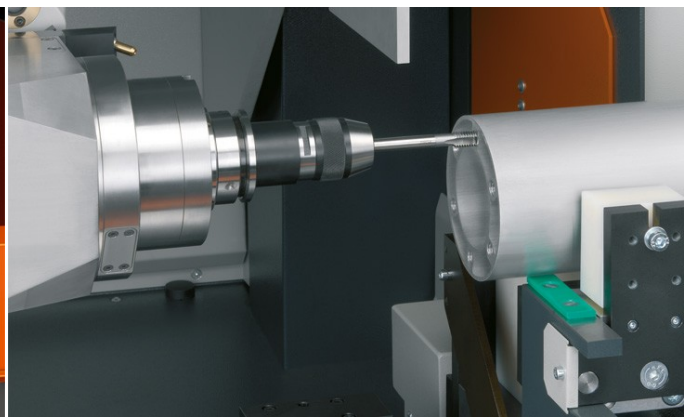

Profile machining centre SBZ 150 eluCam

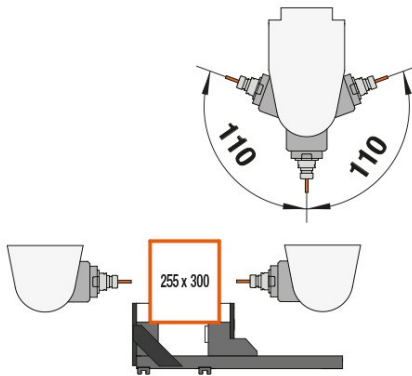

Profile machining centre SBZ 150 eluCam

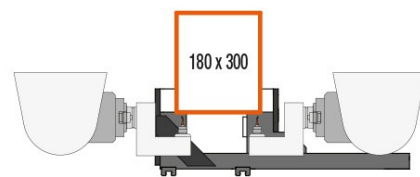

Profile machining centre SBZ 150 eluCam

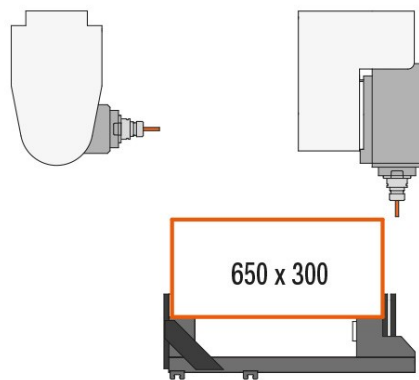

Profile machining centre SBZ 150 eluCam