



DOWSIL™ 993 Structural Glazing Sealant

Two-part silicone rubber

Features & Benefits

- Meets European standard for structural glazing as developed by EOTA working groups
- Excellent adhesion to a wide range of substrates including coated, enamelled and reflective glasses, anodised and polyester paint coated aluminium and stainless steel
- High level of mechanical properties
- Odorless and non-corrosive cure
- Excellent stability through wide temperature range: -50°C to 150°C
- Resistant to ozone
- Stable viscosity for A & B components, no heating required
- Suitable for use in impact-resistant window systems in new construction and retrofit in existing buildings
- Structural capability
- The cured product exhibits excellent weathering characteristics, and a high resistance to ultra-violet radiation, heat and humidity
- Lot matching of base and curing agent not necessary
- Different gray shades available (please refer to our color card)

Applications

- Two-part silicone sealant for structural glazing (SG)

Typical Properties

Specification Writers: These values are not intended for use in preparing specifications.

Test	Property	Unit	Result
Base: As Supplied			
	Color and Consistency		Viscous white paste
	Specific Gravity		1.32
	Viscosity (100s ⁻¹)	mPa.s	150,000
Curing Agent: As Supplied			
	Consistency		Viscous paste
	Specific Gravity		
	Catalyst Black		1.05
	HV/GER Black		1.06
	Clear & Gray Catalyst		1.01

Typical Properties (Cont.)

Test	Property	Unit	Result
	Viscosity (20s ⁻¹)		
	Catalyst Black	mPa.s	25,000
	HV/GER Black	mPa.s	100,000
	Clear & Gray Catalyst	mPa.s	25,000
ASTM ¹ D93	Flash Point - Closed Cup	°C	28
	As Mixed		
	Color and Consistency		White/black/gray ² non-slump paste
	Specific Gravity		1.30
	Viscosity (100s ⁻¹)	mPa.s	40,000
	Working Time (25°C, 50% R.H.)	minutes	10–30
	Tack-free Time (25°C, 50% R.H.)	minutes	80–100
	Corrosiveness		Non-corrosive
	As Cured - After 7 Days at 25°C and 50% RH		
ISO ³ 8339	Tensile Strength	MPa	0.95
ASTM D624	Tear Strength	kN/m	6.0
ISO 8339	Elongation at Break	%	130
ASTM D2240	Durometer Hardness, Shore A		40
	Sealant Dynamic Design Load	Pa	140,000
	Sealant Static Design Load	Pa	11,000
	Service Temperature Range	°C	-50 to +150

1. ASTM: American Society for Testing and Materials.
2. Please refer to our color card.
3. ISO: International Standardisation Organisation.

Description

DOWSIL™ 993 Structural Glazing Sealant is a two-part, neutral curing silicone formulation specifically developed for the structural bonding of glass, metal and other building components. Neutral alkoxy; cures at room temperature giving off a small amount of alcohol.

Technical Specifications and Standards

DOWSIL™ 993 Structural Glazing Sealant combines excellent unprimed adhesion to a wide range of building substrates with high levels of physical properties over a wide range of temperature. It exhibits excellent retention of adhesive and mechanical properties after ageing as detailed by the EOTA Technical guide:

- 1000 hours exposure to ultraviolet radiation in hot water immersion (ISO DIS 11431)
- Resistance to salt spray (ISO 9227 NSS)
- Resistance to SO₂ (ISO 3231)
- Resistance to extreme temperature (ISO 8339)

Technical Specifications and Standards (Cont.)

CE Marked as structural glazing sealant component according to ETAG002, the European Technical Guidelines for structural glazing with a level of attestation of 1. (external quality audit) valid in all EC countries.

Meets structural glazing sealant requirements according to EN13022, SNJF VEC + VI VEC.



RAL Quality Label 520/2-3

Regulation or protocol	Conclusion	Version of regulation or protocol
French VOC régulations	A+	Regulation of March and May 2011 (DEVL1101903D and DEVL1104875A)
French CMR components	Pass	Regulation of April and May 2009 (DEVP0908633A and DEVP0910046A)
AgBB/ABG	Pass	Anforderungen an bauliche Anlagen bezOglich des Gesundheitsschutzes (ABG), Entwurf 31.08.2017/August 2018 (AgBB)
Belgian Regulation	Pass	Royal decree of May 2014 (C-2014/24239)
EMICODE	EC 1 Plus	April 2019
Indoor Air Comfort	Pass	Indoor Air Comfort 6.0 of February 2017
Indoor Air Comfort GOLD	Pass	Indoor Air Comfort GOLD 6.0 of February 2017
BREEAM International	Compliant	BREEAM International New Construction v2.0 (2016)
BREEAM Norway	Pass	BREEAM-NOR New Construction v1.2 (2019)
CDPH	Pass	
M1	Pass	

How to Use

DOWSIL™ 993 Structural Glazing Sealant offers unprimed adhesion to most coated and uncoated glasses as well as most metal spacers. The sealant is compatible with DOWSIL™ neutral curing construction sealants such as DOWSIL™ 791 Silicone Weatherproofing Sealant, and DOWSIL™ neutral curing insulating glass sealants such as DOWSIL™ 3362 HD Insulating Glass Sealant, as well as most commonly used glazing components. It is important when selecting components for a project that adhesion and compatibility tests are carried out, and found to be successful, before the project starts.

How to Use (Cont.) **Mixing and Dispensing**

To obtain the ultimate physical properties from DOWSIL™ 993 Structural Glazing Sealant it is recommended that the base and curing agent are thoroughly mixed using an airless mixing system found on most existing commercially available two-part silicone dispensing machines. Only special, two-part hand mixed cartridge systems endorsed by The Dow Chemical Company should be used to avoid incorporation of air into the material.

DOWSIL™ 993 Structural Glazing Sealant should be mixed in a ratio of 10:1 base to curing agent by weight, or equivalent 7.8:1 by volume for optimal properties. At this mix ratio, the sealant typically exhibits a working time of 10–30 minutes and allows units to be handled within two hours. Small variations in mixing ratio can be tolerated, but these should not exceed 11:1 to 9:1 by weight or 8.9:1 to 7.3:1 by volume to ensure minimum properties are obtained.

Lot matching of DOWSIL™ 993 Structural Glazing Sealant Base and DOWSIL™ 993 Structural Glazing Sealant Curing Agent is not required. Before use it is recommended that the curing agent be stirred to ensure homogeneity of all components. DOWSIL™ 993 Structural Glazing Sealant Curing Agent will react with atmospheric moisture and therefore should not be exposed to air for prolonged periods of time.

Different catalysts are available for DOWSIL™ 993 Structural Glazing Sealant:

- DOWSIL™ 993 Structural Glazing Catalyst is a medium viscosity paste, fast cure, which is suitable for meter mix equipment using a pressure pot or follower plate system for the catalyst.
- DOWSIL™ 993 HV/GER Structural Glazing Catalyst is a viscous paste, fast cure, which is suitable for meter mix equipment that uses a follower plate system for the catalyst.

Preparatory Work

Clean all joints and glazing pockets, removing all foreign matter and contaminants such as grease, oil, dust, water, frost, surface dirt, old sealants, or glazing compounds and protective coatings.

Metal, glass and plastic surfaces should be cleaned by mechanical or solvent procedures. Where used, solvent should be wiped on and off with clean, oil- and lint-free cloths.

Priming

Priming is not usually required when using DOWSIL™ 993 Structural Glazing Sealant. However, it is essential that adhesion be tested prior to use. Specific primer recommendations will be made by the technical services department on a project basis. Please contact your representative for further advice.

Masking and Tooling

Areas adjacent to joints may be masked to ensure a neat sealant line. Do not allow masking tape to touch clean surfaces to which the silicone sealant is to adhere. Tooling should be completed in one continuous stroke within 5 minutes after sealant application. Masking tape should be removed immediately after tooling.

How to Use (Cont.)**Equipment Cleaning**

When not being used it is recommended that the dispensing equipment be purged either with the base component, or flushed with a suitable solvent such as DOWSIL™ 3522 Concentrated Cleaning Solvent. If cured sealant has built up inside the equipment, flush the equipment for the appropriate time with DOWSIL™ 3522 Concentrated Cleaning Solvent, using a solvent recirculation system. This solvent dissolves cured silicone sealant and provides optimum cleaning performance.

Maintenance

No maintenance is needed. If sealant becomes damaged, replace damaged portion. DOWSIL™ 993 Structural Glazing Sealant will adhere to compatible cured silicone sealant which exhibits a clean knife-cut or abraded surface.

**Handling
Precautions**

PRODUCT SAFETY INFORMATION REQUIRED FOR SAFE USE IS NOT INCLUDED IN THIS DOCUMENT. BEFORE HANDLING, READ PRODUCT AND SAFETY DATA SHEETS AND CONTAINER LABELS FOR SAFE USE, PHYSICAL AND HEALTH HAZARD INFORMATION. THE SAFETY DATA SHEET IS AVAILABLE ON THE DOW WEBSITE AT DOW.COM, OR FROM YOUR DOW SALES APPLICATION ENGINEER, OR DISTRIBUTOR, OR BY CALLING DOW CUSTOMER SERVICE.

**Usable Life and
Storage**

When stored at or below 30°C, DOWSIL™ 993 Structural Glazing Sealant Curing Agent has a usable life of 14 months from the date of production.

When stored at or below 30°C, DOWSIL™ 993 Structural Glazing Sealant Base has a usable life of 14 months from the date of production.

DOWSIL™ 993 Repair-kit cartridge has a usable life of 9 months from the date of the filling.

**Packaging
Information**

DOWSIL™ 993 Structural Glazing Sealant Base is available in 250 kg drums and 20 liter pails.

DOWSIL™ 993 Structural Glazing Sealant Curing Agent is available in 25 kg pails and 675 ml side-by-side-cartridge (carton with 10 cartridges and 10 static mixers).

Beside black and clear, the curing agent is offered in a variety of gray shades. Custom colors may be available on request.

Limitations

This product is neither tested nor represented as suitable for medical or pharmaceutical uses.

**Health and
Environmental
Information**

To support customers in their product safety needs, Dow has an extensive Product Stewardship organization and a team of product safety and regulatory compliance specialists available in each area.

For further information, please see our website, dow.com or consult your local Dow representative.

Disposal Considerations

Dispose in accordance with all local, state (provincial) and federal regulations. Empty containers may contain hazardous residues. This material and its container must be disposed in a safe and legal manner.

It is the user's responsibility to verify that treatment and disposal procedures comply with local, state (provincial) and federal regulations. Contact your Dow Technical Representative for more information.

Product Stewardship

Dow has a fundamental concern for all who make, distribute, and use its products, and for the environment in which we live. This concern is the basis for our product stewardship philosophy by which we assess the safety, health, and environmental information on our products and then take appropriate steps to protect employee and public health and our environment. The success of our product stewardship program rests with each and every individual involved with Dow products - from the initial concept and research, to manufacture, use, sale, disposal, and recycle of each product.

Customer Notice

Dow strongly encourages its customers to review both their manufacturing processes and their applications of Dow products from the standpoint of human health and environmental quality to ensure that Dow products are not used in ways for which they are not intended or tested. Dow personnel are available to answer your questions and to provide reasonable technical support. Dow product literature, including safety data sheets, should be consulted prior to use of Dow products. Current safety data sheets are available from Dow.

Application Examples

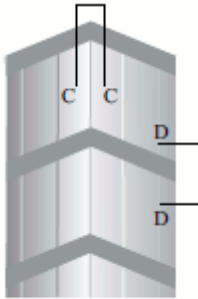

Figure 1: System for 4-sided structural glazing.

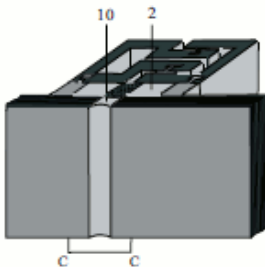

Figure 1A: Section CC: 4-sided design – unsupported glass.

Application Examples (Cont.)

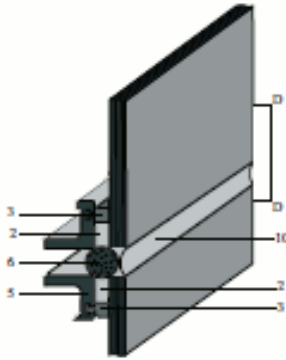

Figure 1B: Section DD: 4-sided Design – unsupported glass.

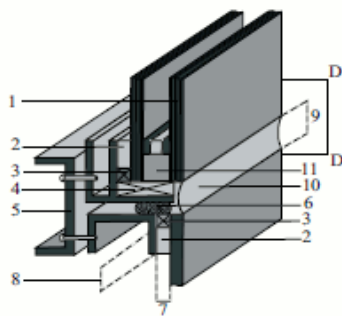

Figure 2: Section DD: 4-sided design – supported insulating glass unit.

Legend

1. Insulating glass unit
2. Silicone structural seal (DOWSIL™ 993 Structural Glazing Sealant)
3. Silicone rubber spacer block
4. Silicone setting block
5. Aluminium profile
6. Backer rod
7. Structural sealant width dimension
8. Structural sealant bite dimension
9. Weatherseal dimension
10. Silicone weatherseal (DOWSIL™ 791 Silicone Weatherproofing Sealant)
11. Silicone insulated glass seal

Application Examples (Cont.)

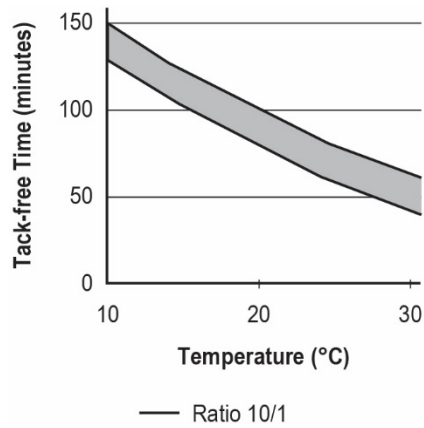

Figure 3: DOWSIL™ 993 Structural Glazing Sealant – Tack-free time range.

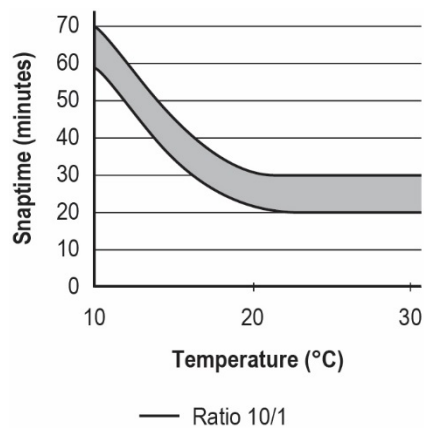

Figure 4: DOWSIL™ 993 Structural Glazing Sealant – Snaptime range.

dow.com

NOTICE: No freedom from infringement of any patent owned by Dow or others is to be inferred. Because use conditions and applicable laws may differ from one location to another and may change with time, Customer is responsible for determining whether products and the information in this document are appropriate for Customer's use and for ensuring that Customer's workplace and disposal practices are in compliance with applicable laws and other government enactments. The product shown in this literature may not be available for sale and/or available in all geographies where Dow is represented. The claims made may not have been approved for use in all countries. Dow assumes no obligation or liability for the information in this document. References to "Dow" or the "Company" mean the Dow legal entity selling the products to Customer unless otherwise expressly noted. NO WARRANTIES ARE GIVEN; ALL IMPLIED WARRANTIES OF MERCHANTABILITY OR FITNESS FOR A PARTICULAR PURPOSE ARE EXPRESSLY EXCLUDED.

