



# TOOL LIST

THE PERFECT SOLUTION FOR EVERY REQUIREMENT



# CONTENTS

<b>INTRODUCTION</b>		Page 3
<b>1   TOOLS FOR ALUMINIUM</b>		
<b>1.1   DRILLING</b>	HSS twist drill, type N HSS twist drill, type Uni with TiN coating	Page 4 Page 5
<b>1.2   MILLING</b>	HSS milling cutter, short version HSS milling cutter, medium version HSS milling cutter, long version HM milling cutter, short version HM milling cutter, medium version HM milling cutter, long version	Page 6 Page 7 Page 8 Page 8/9 Page 10 Page 11
<b>1.3   THREADS</b>	HSS screw tap HSS combination screw tap Friction drill, long/flat Aludrill friction drill Thread former and solid carbide thread milling cutter	Page 12 Page 13 Page 14 Page 15 Page 16
<b>1.4   SAWING, NOTCHING</b>	Disc milling cutters Holder for disc milling cutters Saw blades	Page 17 Page 17 Page 18
<b>1.5   SPECIAL TOOLS</b>	Milling cutter with HM inserts HSS step drill, short Multifunctional milling cutter, 90° HM milling cutter with AL-LF coating Milling cutter diamond-tipped with PCD	Page 19 Page 20 Page 20 Page 21 Page 22
<b>2   TOOLS FOR STEEL</b>		
<b>2.1   DRILLING</b>	HSS twist drill, type N HSS twist drill, type Uni with TiN coating	Page 23 Page 24
<b>2.2   MILLING</b>	PM / HM milling cutter	Page 25
<b>2.3   THREADS</b>	Friction drill, long/flat, and thread former	Page 26
<b>2.4   SAWING</b>	Saw blades	Page 27
<b>3   TOOLS FOR STAINLESS STEEL/INOX</b>		
<b>3.1   DRILLING</b>	HSS twist drill, type Uni with TiN coating	Page 27/28
<b>3.2   MILLING</b>	PM / HM milling cutter with coating	Page 29
<b>3.3   THREADS</b>	HSS screw tap	Page 30
<b>4   TOOLS FOR PVC</b>		
<b>4.1   DRILLING</b>	HSS twist drill, type Uni with TiN coating	Page 31
<b>4.2   MILLING</b>	HM milling	Page 32
<b>5   APPLICATION EXAMPLES</b>		
<b>5.1   TOOLS FOR MACHINING PVC DOORS WITH STEEL REINFORCEMENT FOR SBZ 122</b>		Page 33
<b>5.2   TOOLS FOR PROCESSING STRUCTURAL PROFILES</b>		Page 34
<b>5.3   TOOLS FOR MACHINING PVC DOORS WITH STEEL REINFORCEMENT FOR SBZ 130</b>		Page 35
<b>5.4   TOOLS FOR MACHINING STAINLESS STEEL ROUND TUBES/RAILINGS</b>		Page 36
<b>5.5   TOOLS FOR MACHINING FURNITURE PROFILES</b>		Page 37
<b>5.6   MACHINING POST PROFILES IN METAL CONSTRUCTION</b>		Page 38
<b>5.7   MACHINING SANDWICH PANELS FOR SECTIONAL DOORS</b>		Page 39
<b>6   ACCESSORIES</b>		
<b>6.1   ER 32, ER 25, ER 20, ER 16 COLLETS</b>		Page 40
<b>6.2   ER COLLETS WITH COMPENSATION SPRING FOR SCREW TAPS, ER 077, S8, OZ COLLETS</b>		Page 41
<b>6.3   HSK-F 63 CLAMPING ADAPTERS</b>		Page 42
<b>6.4   CLAMPING ADAPTERS FOR SBZ 130 AND SBZ 131</b>		Page 43
<b>6.5   LUBRICANTS AND COOLANTS</b>		Page 44
<b>7   OTHER</b>		
<b>7.1   OPTIMISING THE SERVICE LIFE OF TOOLS AND SPINDLES</b>		Page 45

# INTRODUCTION

Dear customer,

When you buy a machine from elumatec, you know you are getting high quality and performance! But this is only guaranteed if suitable and tested tools are used. We have therefore compiled a selection of elumatec tools for you in this tool catalogue.

All data given is geared to the needs of metal construction. It serves as general guidelines and can be optimised if necessary. The underlying materials are aluminium profiles in wrought alloys, structural steel and stainless steel in profile form. The preferred tools are printed in bold, whether or not they can be used depending on the machine and equipment (e.g. drilling in aluminium with a diameter of 20 mm for SBZ 122).

**Following these guidelines will increase production quality and tool service life, reduce machining times and minimise noise:**

- Clamp the workpiece firmly and securely (with at least two pneumatic clamps or a vice holding the profile).  
The maximum distance between the clamps depends on the profile)
- Clamp the workpiece close to where it will be machined
- Clamp tools for as short a time as possible
- Aim sprays carefully to aid machining
- Use elumatec sprays in the required quantity
- For hard metal tools, ensure the collets and the tool holders move smoothly
- Only use well-balanced tool systems
- Ensure synchronous running – avoid counter rotation

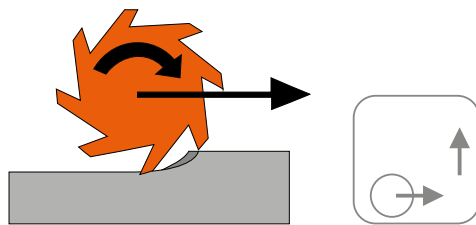

Synchronous running

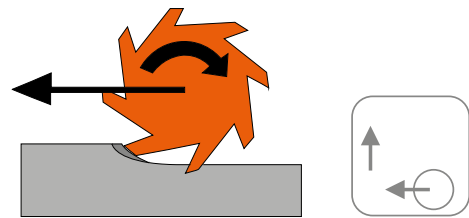

Counter rotation

If you have any questions about these issues, selecting the right tools or optimising your processes, please do not hesitate to contact us. We hope you enjoy browsing through the catalogue, and we look forward to receiving your order!

## elumatec AG

Technical department  
Pinacher Straße 61  
75417 Mühlacker  
Germany



Phone +49 7041 14 - 105  
Fax +49 7041 14 - 282

sales@elumatec.com  
www.elumatec.com

## 1.1 | DRILLING

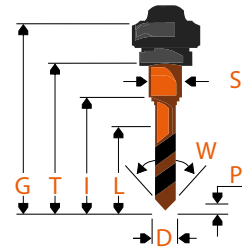
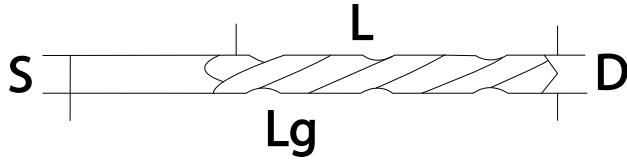
HSS twist drill, DIN 338, 5xD, type N for aluminium





ALU	D	L	Lg	S	Z			Order no.
< 2 mm	2.5 mm	30 mm	57 mm	2.5 mm	2	6,000 rpm	400 mm/min	060 3000 0250
< 3 mm	3 mm	33 mm	61 mm	3 mm	2	6,000 rpm	500 mm/min	060 3000 0300
< 3 mm	3.3 mm	33 mm	65 mm	3.3 mm	2	6,000 rpm	500 mm/min	060 3000 0330
< 4 mm	4.2 mm	43 mm	75 mm	4.2 mm	2	5,300 rpm	500 mm/min	060 3000 0420
< 5 mm	5 mm	52 mm	86 mm	5 mm	2	4,460 rpm	500 mm/min	060 3000 0500
< 6 mm	6 mm	57 mm	93 mm	6 mm	2	3,710 rpm	500 mm/min	060 3000 0600
< 6 mm	6.8 mm	69 mm	109 mm	6.8 mm	2	3,270 rpm	500 mm/min	060 3000 0680
< 8 mm	8 mm	75 mm	117 mm	8 mm	2	2,780 rpm	500 mm/min	060 3000 0800
< 8 mm	8.5 mm	75 mm	117 mm	8.5 mm	2	2,620 rpm	500 mm/min	060 3000 0850
< 10 mm	10 mm	87 mm	133 mm	10 mm	2	2,230 rpm	500 mm/min	060 3000 1000
< 10 mm	11 mm	94 mm	142 mm	11 mm	2	2,020 rpm	400 mm/min	060 3000 1100
< 10 mm	12 mm	101 mm	151 mm	12 mm	2	1,860 rpm	400 mm/min	060 3000 1200
< 10 mm	15 mm	114 mm	169 mm	15 mm	2	1,500 rpm	400 mm/min	060 3000 1500

# 1.1 | DRILLING

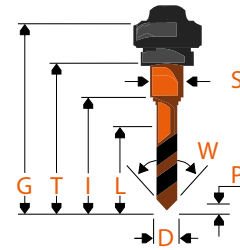
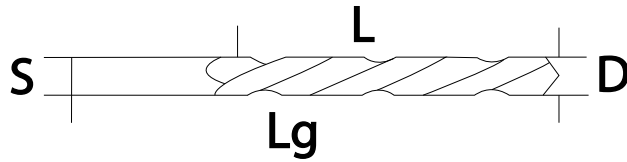
HSS twist drill, DIN 338, 5xD, type Uni with TiN coating for aluminium



ALU	D	L	Lg	S	Z			Order no.
< 2 mm	2.5 mm	30 mm	57 mm	2.5 mm	2	8,500 rpm	850 mm/min	060 3090 0250
< 3 mm	3 mm	33 mm	61 mm	3 mm	2	7,100 rpm	900 mm/min	060 3090 0300
< 3 mm	3.2 mm	36 mm	65 mm	3.2 mm	2	6,650 rpm	900 mm/min	060 3090 0320
< 3 mm	3.3 mm	36 mm	65 mm	3.3 mm	2	6,450 rpm	900 mm/min	060 3090 0330
< 3 mm	3.5 mm	39 mm	70 mm	3.5 mm	2	6,100 rpm	880 mm/min	060 3090 0350
< 4 mm	4 mm	43 mm	75 mm	4 mm	2	5,300 rpm	850 mm/min	060 3090 0400
< 4 mm	4.2 mm	43 mm	75 mm	4.2 mm	2	5,080 rpm	820 mm/min	060 3090 0420
< 4 mm	4.5 mm	47 mm	75 mm	4.5 mm	2	4,750 rpm	800 mm/min	060 3090 0450
< 5 mm	5 mm	52 mm	86 mm	5 mm	2	4,270 rpm	760 mm/min	060 3090 0500
< 5 mm	5.5 mm	57 mm	93 mm	5.5 mm	2	3,900 rpm	730 mm/min	060 3090 0550
< 6 mm	6 mm	57 mm	93 mm	6 mm	2	3,560 rpm	700 mm/min	060 3090 0600
< 6 mm	6.5 mm	63 mm	101 mm	6.5 mm	2	3,300 rpm	680 mm/min	060 3090 0650
< 6 mm	6.8 mm	69 mm	109 mm	6.8 mm	2	3,140 rpm	680 mm/min	060 3090 0680
< 7 mm	7 mm	69 mm	109 mm	7 mm	2	3,050 rpm	680 mm/min	060 3090 0700
< 8 mm	8 mm	75 mm	117 mm	8 mm	2	2,670 rpm	660 mm/min	060 3090 0800
< 8 mm	8.5 mm	75 mm	117 mm	8.5 mm	2	2,510 rpm	660 mm/min	060 3090 0850
< 9 mm	9 mm	81 mm	125 mm	9 mm	2	2,370 rpm	680 mm/min	060 3090 0900
< 10 mm	10 mm	87 mm	133 mm	10 mm	2	2,130 rpm	720 mm/min	060 3090 1000
< 10 mm	10.5 mm	87 mm	133 mm	10.5 mm	2	2,030 rpm	700 mm/min	060 3090 1050
< 10 mm	11 mm	94 mm	142 mm	11 mm	2	1,940 rpm	670 mm/min	060 3090 1100
< 10 mm	12 mm	101 mm	151 mm	12 mm	2	1,780 rpm	620 mm/min	060 3090 1200
< 10 mm	13 mm	101 mm	151 mm	13 mm	2	1,630 rpm	570 mm/min	060 3090 1300
< 10 mm	14 mm	108 mm	160 mm	14 mm	2	1,520 rpm	530 mm/min	060 3090 1400

## 1.2 | MILLING

### HSS milling cutter for aluminium, short version

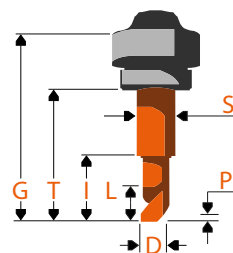
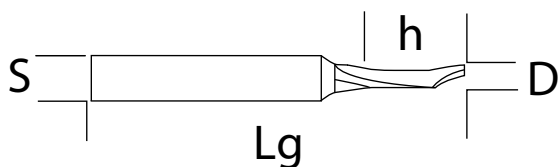

ALU	D	h(L)	Lg	T	S	Z				Order no.
< 1.5 mm	3 mm	10 mm	60 mm	40 mm	8 mm	1	16,000 rpm	600 mm/min	250 mm/min	068 3650 03
							19,000 rpm	760 mm/min	300 mm/min	alternative
							8,000 rpm	300 mm/min	130 mm/min	alternative
							6,000 rpm	250 mm/min	110 mm/min	alternative
< 2 mm	4 mm	12 mm	60 mm	40 mm	8 mm	1	12,000 rpm	500 mm/min	200 mm/min	068 3650 04
							17,500 rpm	700 mm/min	280 mm/min	alternative
							8,000 rpm	300 mm/min	130 mm/min	alternative
							6,000 rpm	250 mm/min	110 mm/min	alternative
< 2 mm	5 mm	14 mm	60 mm	40 mm	8 mm	1	12,000 rpm	550 mm/min	220 mm/min	068 3650 05
							15,000 rpm	700 mm/min	280 mm/min	alternative
							8,000 rpm	350 mm/min	150 mm/min	alternative
							6,000 rpm	300 mm/min	130 mm/min	alternative
< 2.5 mm	6 mm	14 mm	60 mm	40 mm	8 mm	1	9,500 rpm	500 mm/min	200 mm/min	068 3650 06
							15,000 rpm	750 mm/min	300 mm/min	alternative
							8,000 rpm	400 mm/min	160 mm/min	alternative
							6,000 rpm	350 mm/min	130 mm/min	alternative
< 2.5 mm	7 mm	14 mm	60 mm	40 mm	8 mm	1	8,200 rpm	400 mm/min	200 mm/min	068 3650 07
							15,000 rpm	750 mm/min	300 mm/min	alternative
							8,000 rpm	400 mm/min	160 mm/min	alternative
							6,000 rpm	350 mm/min	130 mm/min	alternative
< 3 mm	8 mm	14 mm	80 mm	40 mm	8 mm	1	8,000 rpm	400 mm/min	200 mm/min	068 3650 08
							15,000 rpm	800 mm/min	350 mm/min	alternative
							6,000 rpm	350 mm/min	150 mm/min	alternative
< 2 mm	8 mm	19 mm	70 mm	40 mm	10 mm	2	7,200 rpm	500 mm/min	200 mm/min	150 3660 08
							10,000 rpm	1,000 mm/min	300 mm/min	alternative
< 3 mm	10 mm	22 mm	72 mm	40 mm	10 mm	2	5,700 rpm	500 mm/min	200 mm/min	150 3660 10
							10,000 rpm	700 mm/min	300 mm/min	alternative

## 1.2 | MILLING

### HSS milling cutter for aluminium, medium version

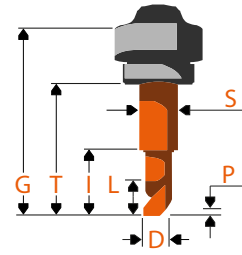
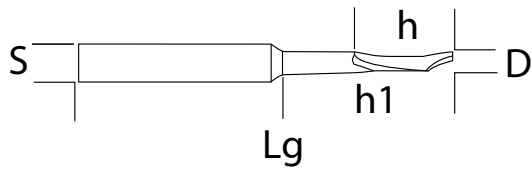



ALU	D	h(L)	Lg	h1(l)	T	S	Z					Order no.
< 2 mm	3.2 mm	10 mm	80 mm	33 mm	55 mm	8 mm	1	<b>18,000 rpm</b>	<b>400 mm/min</b>	<b>220 mm/min</b>		<b>060 4099 0097</b>
								8,000 rpm	200 mm/min	150 mm/min	alternative	
								6,000 rpm	180 mm/min	140 mm/min	alternative	
< 2 mm	4.2 mm	10 mm	80 mm	33 mm	55 mm	8 mm	1	<b>14,000 rpm</b>	<b>400 mm/min</b>	<b>220 mm/min</b>		<b>060 4099 0098</b>
								8,000 rpm	220 mm/min	160 mm/min	alternative	
								6,000 rpm	180 mm/min	140 mm/min	alternative	
< 2 mm	5 mm	14 mm	80 mm	33 mm	55 mm	8 mm	1	<b>12,000 rpm</b>	<b>550 mm/min</b>	<b>220 mm/min</b>		<b>068 3650 19</b>
								15,000 rpm	700 mm/min	280 mm/min	alternative	
								8,000 rpm	350 mm/min	150 mm/min	alternative	
< 3 mm	6 mm	14 mm	80 mm	35 mm	55 mm	8 mm	1	<b>9,500 rpm</b>	<b>500 mm/min</b>	<b>200 mm/min</b>		<b>068 3650 23</b>
								15,000 rpm	700 mm/min	280 mm/min	alternative	
								8,000 rpm	400 mm/min	150 mm/min	alternative	
< 3 mm	8 mm	14 mm	80 mm	55 mm	55 mm	8 mm	1	<b>8,000 rpm</b>	<b>400 mm/min</b>	<b>200 mm/min</b>		<b>068 3650 22</b>
								15,000 rpm	800 mm/min	350 mm/min	alternative	
								6,000 rpm	350 mm/min	150 mm/min	alternative	
< 3 mm	9 mm	14 mm	80 mm	40 mm	40 mm	8 mm	1	<b>6,000 rpm</b>	<b>300 mm/min</b>	<b>130 mm/min</b>		<b>068 3650 09</b>
								13,500 rpm	750 mm/min	300 mm/min	alternative	
								8,000 rpm	400 mm/min	160 mm/min	alternative	
< 3 mm	10 mm	14 mm	80 mm	40 mm	40 mm	8 mm	1	<b>5,800 rpm</b>	<b>300 mm/min</b>	<b>110 mm/min</b>		<b>068 3650 10</b>
								12,000 rpm	700 mm/min	280 mm/min	alternative	
								8,000 rpm	400 mm/min	160 mm/min	alternative	
< 3 mm	10 mm	14 mm	80 mm	60 mm	60 mm	10 mm	1	<b>5,800 rpm</b>	<b>300 mm/min</b>	<b>110 mm/min</b>		<b>078 3650 10</b>
								12,000 rpm	700 mm/min	280 mm/min	alternative	
								8,000 rpm	400 mm/min	160 mm/min	alternative	
< 3 mm	10 mm	22 mm	100 mm	60 mm	60 mm	10 mm	2	<b>5,700 rpm</b>	<b>500 mm/min</b>	<b>200 mm/min</b>		<b>178 3660 10</b>
< 3 mm	12 mm	14 mm	80 mm	40 mm	40 mm	8 mm	1	<b>4,800 rpm</b>	<b>250 mm/min</b>	<b>110 mm/min</b>		<b>068 3650 12</b>
								10,000 rpm	600 mm/min	220 mm/min	alternative	
								8,000 rpm	400 mm/min	160 mm/min	alternative	
< 3 mm	20 mm	14 mm	90 mm	55 mm	55 mm	10 mm	2	<b>2,850 rpm</b>	<b>300 mm/min</b>	<b>100 mm/min</b>		<b>078 3650 21</b>
								6,000 rpm	600 mm/min	200 mm/min	alternative	

## 1.2 | MILLING

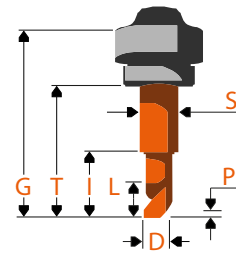
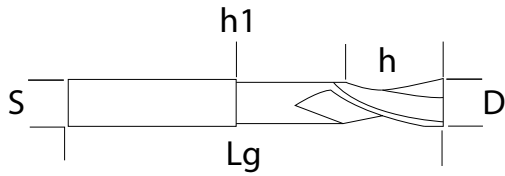

### HSS milling cutter for aluminium, long version



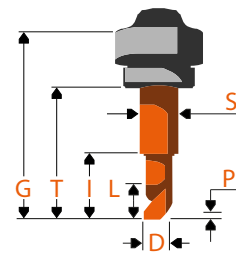
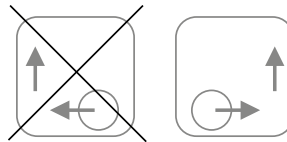
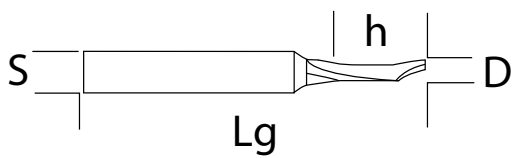

ALU	D	h(L)	Lg	h1(l)	T	S	Z				Order no.
< 2 mm	5 mm	14 mm	120 mm	25 mm	80 mm	8 mm	1	12,000 rpm	550 mm/min	220 mm/min	
								17,500 rpm	700 mm/min	280 mm/min	alternative
								8,000 rpm	300 mm/min	130 mm/min	alternative
< 2 mm	7 mm	14 mm	80 mm	60 mm	60 mm	8 mm	2	8,200 rpm	400 mm/min	200 mm/min	
								15,000 rpm	750 mm/min	300 mm/min	alternative
								8,000 rpm	400 mm/min	160 mm/min	alternative
< 2 mm	8 mm	14 mm	100 mm	62 mm	70 mm	10 mm	1	8,000 rpm	400 mm/min	200 mm/min	
								6,000 rpm	300 mm/min	130 mm/min	alternative
< 3 mm	10 mm	22 mm	120 mm	70 mm	80 mm	10 mm	2	5,700 rpm	500 mm/min	200 mm/min	
< 3 mm	20 mm	38 mm	104 mm	38 mm	65 mm	20 mm	3	2,850 rpm	400 mm/min	100 mm/min	

### HM milling cutter for aluminium, short version



ALU	D	h(L)	Lg	T	S	Z				Order no.
< 1.5 mm	2 mm	7 mm	70 mm	45 mm	8 mm	1	18,000 rpm	600 mm/min	300 mm/min	
							12,000 rpm	400 mm/min	200 mm/min	alternative
< 2 mm	3 mm	10 mm	70 mm	40 mm	8 mm	1	18,000 rpm	900 mm/min	350 mm/min	
							12,000 rpm	600 mm/min	300 mm/min	alternative
							8,000 rpm	400 mm/min	200 mm/min	alternative





ALU	D	h(L)	Lg	T	S	Z					Order no.
< 2 mm	4 mm	10 mm	70 mm	40 mm	8 mm	1	<b>18,000 rpm</b>	<b>900 mm/min</b>	<b>350 mm/min</b>		<b>140 3901 04</b>
							12,000 rpm	600 mm/min	300 mm/min	alternative	
							8,000 rpm	400 mm/min	200 mm/min	alternative	
< 2 mm	5 mm	16 mm	70 mm	40 mm	8 mm	1	<b>18,000 rpm</b>	<b>1,000 mm/min</b>	<b>350 mm/min</b>		<b>140 3901 05</b>
							12,000 rpm	650 mm/min	300 mm/min	alternative	
							8,000 rpm	440 mm/min	200 mm/min	alternative	
< 3 mm	6 mm	16 mm	70 mm	40 mm	8 mm	1	<b>18,000 rpm</b>	<b>1,000 mm/min</b>	<b>350 mm/min</b>		<b>140 3901 06</b>
							12,000 rpm	650 mm/min	300 mm/min	alternative	
							8,000 rpm	440 mm/min	200 mm/min	alternative	
< 3 mm	7 mm	22 mm	70 mm	40 mm	8 mm	1	<b>18,000 rpm</b>	<b>1,100 mm/min</b>	<b>350 mm/min</b>		<b>140 3901 07</b>
							12,000 rpm	700 mm/min	300 mm/min	alternative	
							8,000 rpm	460 mm/min	200 mm/min	alternative	
< 3 mm	8 mm	22 mm	70 mm	40 mm	8 mm	1	<b>18,000 rpm</b>	<b>1,100 mm/min</b>	<b>350 mm/min</b>		<b>140 3901 08</b>
							12,000 rpm	700 mm/min	300 mm/min	alternative	
							8,000 rpm	460 mm/min	200 mm/min	alternative	
< 3 mm	9 mm	22 mm	70 mm	40 mm	10 mm	1	<b>18,000 rpm</b>	<b>1,100 mm/min</b>	<b>350 mm/min</b>		<b>060 4099 0509</b>
							6,000 rpm	350 mm/min	150 mm/min	alternative	
< 4 mm	10 mm	22 mm	70 mm	40 mm	10 mm	1	<b>18,000 rpm</b>	<b>1,200 mm/min</b>	<b>350 mm/min</b>		<b>140 3901 10</b>
							12,000 rpm	800 mm/min	300 mm/min	alternative	
							8,000 rpm	500 mm/min	200 mm/min	alternative	
< 3 mm	10 mm	22 mm	70 mm	40 mm	10 mm	2	<b>24,000 rpm</b>	<b>3,000 mm/min</b>	<b>400 mm/min</b>		<b>140 3902 10</b>
< 6 mm	12 mm	25/40 mm	80 mm	40 mm	12 mm	1	<b>18,000 rpm</b>	<b>1,800 mm/min</b>	<b>350 mm/min</b>		<b>140 3901 12</b>
							12,000 rpm	1,200 mm/min	300 mm/min	alternative	
							8,000 rpm	800 mm/min	200 mm/min	alternative	
< 4 mm	12 mm	22 mm	70 mm	40 mm	12 mm	2	<b>18,000 rpm</b>	<b>1,800 mm/min</b>	<b>350 mm/min</b>		<b>140 3902 12</b>
							12,000 rpm	1,200 mm/min	300 mm/min	alternative	
							8,000 rpm	800 mm/min	200 mm/min	alternative	
< 5 mm	16 mm	22 mm	70 mm	40 mm	16 mm	2	<b>18,000 rpm</b>	<b>1,800 mm/min</b>	<b>350 mm/min</b>		<b>140 3902 16</b>
							12,000 rpm	1,200 mm/min	300 mm/min	alternative	
							8,000 rpm	800 mm/min	200 mm/min	alternative	

## 1.2 | MILLING

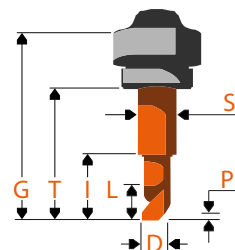
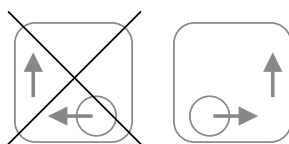
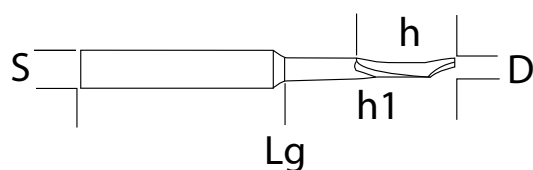
### HM milling cutter for aluminium, medium version

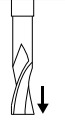

ALU	D	h(L)	Lg	h1(l)	T	S	Z					Order no.
< 2 mm	5 mm	20 mm	80 mm	25 mm	50 mm	8 mm	1	18,000 rpm	800 mm/min	300 mm/min		140 3911 05 and 141 3911 05
								12,000 rpm	600 mm/min	280 mm/min	alternative	
								8,000 rpm	400 mm/min	250 mm/min	alternative	
< 2 mm	8 mm	22 mm	80 mm	40 mm	50 mm	8 mm	1	16,000 rpm	800 mm/min	300 mm/min		140 3911 08 141 3911 08
								12,000 rpm	600 mm/min	250 mm/min	alternative	
< 3 mm	10 mm	12 mm	90 mm	60 mm	65 mm	10 mm	2	15,000 rpm	800 mm/min	350 mm/min		140 3912 10 and 141 3912 10
								12,000 rpm	600 mm/min	250 mm/min	alternative	
< 3 mm	12 mm	12 mm	100 mm	60 mm	65 mm	12 mm	2	18,000 rpm	1,200 mm/min	350 mm/min		140 3912 12 and 141 3912 12
								12,000 rpm	600 mm/min	250 mm/min	alternative	
< 4 mm	16 mm	32 mm	102 mm	60 mm	70 mm	16 mm	3	18,000 rpm	1,500 mm/min	300 mm/min		140 3913 16 and 141 3913 16
								12,000 rpm	1,000 mm/min	200 mm/min	alternative	
< 3 mm	16 mm	32 mm	110 mm	75 mm	80 mm	16 mm	3	16,000 rpm	1,200 mm/min	300 mm/min		140 3913 17
								12,000 rpm	800 mm/min	200 mm/min	alternative	
< 5 mm	16 mm	32 mm	92 mm	32 mm	65 mm	16 mm	3	18,000 rpm	2,200 mm/min	300 mm/min	Rough toothing	060 4099 0087
								12,000 rpm	1,500 mm/min	200 mm/min	alternative	

## 1.2 | MILLING

### HM milling cutter for aluminium, long version

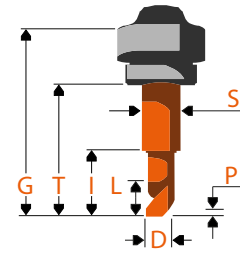
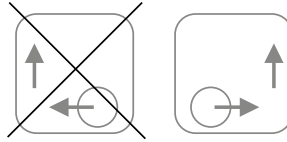
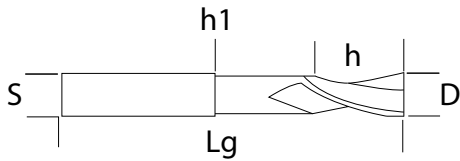





ALU	D	h(L)	Lg	h1(l)	T	S	Z					Order no.
< 1.8 mm	3.5 mm	10 mm	80 mm	40 mm	50 mm	8 mm	1	18,000 rpm	500 mm/min	300 mm/min		140 3921 035
< 1.8 mm	4 mm	10 mm	80 mm	40 mm	50 mm	8 mm	1	18,000 rpm	600 mm/min	350 mm/min		140 3921 04
								12,000 rpm	450 mm/min	250 mm/min	alternative	
< 2 mm	5 mm	10 mm	80 mm	40 mm	50 mm	8 mm	1	15,000 rpm	700 mm/min	350 mm/min		140 3921 05
								21,000 rpm	600 mm/min	300 mm/min	alternative	
								8,000 rpm	380 mm/min	250 mm/min	alternative	
< 2 mm	6 mm	10 mm	80 mm	40 mm	50 mm	8 mm	1	12,000 rpm	700 mm/min	350 mm/min		140 3921 06
								8,000 rpm	500 mm/min	250 mm/min	alternative	
< 2 mm	8 mm	12 mm	80 mm	55 mm	58 mm	8 mm	2	8,000 rpm	700 mm/min	250 mm/min	*	140 3922 08
								12,000 rpm	1,100 mm/min	350 mm/min	alternative	
< 2 mm	10 mm	12 mm	110 mm	80 mm	80 mm	10 mm	2	8,000 rpm	600 mm/min	250 mm/min	*	140 3922 10
								5,000 rpm	450 mm/min	220 mm/min	alternative	
< 5 mm	16 mm	20 mm	115 mm	60 mm	75 mm	16 mm	2	18,000 rpm	1,800 mm/min	350 mm/min		060 4099 0041
								12,000 rpm	1,200 mm/min	250 mm/min	alternative	
< 3 mm	16 mm	32 mm	130 mm	90 mm	95 mm	16 mm	3	18,000 rpm	1,200 mm/min	300 mm/min	*	060 4099 0542
								12,000 rpm	1,000 mm/min	230 mm/min	alternative	
< 6 mm	20 mm	20 mm	125 mm	70 mm	85 mm	20 mm	2	16,000 rpm	1,800 mm/min	350 mm/min		060 4099 0042
								12,000 rpm	1,200 mm/min	230 mm/min	alternative	

\* Only use if no other tool is available.  
 Clamp tool firmly.  
 Use tool holder with concentric running better than +/- 0.01 mm.

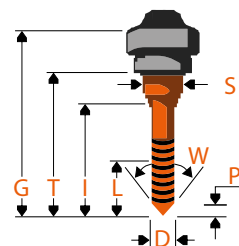
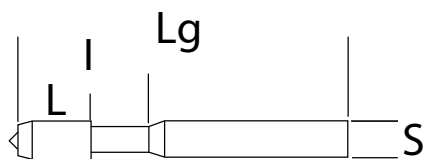
### 1.3 | THREADS

#### HSS screw tap for aluminium





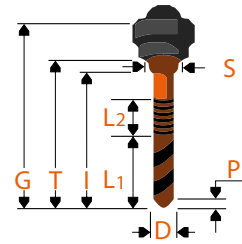
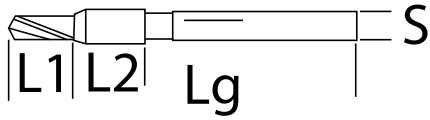

Thread		Lg	I	S	L				Order no.
M3	0.5 mm	56 mm	18 mm	3.5 mm	6 mm	<b>1,000 rpm</b>	<b>500 mm/min</b>		<b>060 3502 0300</b>
						800 rpm	400 mm/min	alternative	
M4	0.7 mm	63 mm	21 mm	4.5 mm	7 mm	<b>1,000 rpm</b>	<b>700 mm/min</b>		<b>060 3508 0400</b>
						800 rpm	560 mm/min	alternative	
M5	0.8 mm	70 mm	25 mm	6 mm	8 mm	<b>1,000 rpm</b>	<b>800 mm/min</b>		<b>060 3508 0500</b>
						1,200 rpm	960 mm/min	alternative	
M6	1 mm	80 mm	30 mm	6 mm	10 mm	<b>1,000 rpm</b>	<b>1,000 mm/min</b>		<b>060 3508 0600</b>
						1,200 rpm	1,200 mm/min	alternative	
M8	1.25 mm	90 mm	35 mm	8 mm	14 mm	<b>800 rpm</b>	<b>1,000 mm/min</b>		<b>060 3508 0800</b>
						600 rpm	750 mm/min	alternative	
M10	1.5 mm	100 mm	39 mm	10 mm	16 mm	<b>800 rpm</b>	<b>1,200 mm/min</b>		<b>060 3508 1000</b>
						600 rpm	900 mm/min	alternative	

### 1.3 | THREADS

#### HSS combination screw tap for aluminium



Thread		Lg	L1	I	S					Order no.
M4	0.7 mm	66 mm	10 mm	25 mm	4.5 mm	6,000 rpm	400 mm/min	1,000 rpm	700 mm/min	060 3560 0400
M5	0.8 mm	75 mm	12 mm	35 mm	6 mm	5,300 rpm	400 mm/min	1,000 rpm	800 mm/min	060 3560 0500
M6	1 mm	81 mm	14 mm	35 mm	6 mm	4,500 rpm	400 mm/min	1,000 rpm	1,000 mm/min	060 3560 0600
M8	1.25 mm	93 mm	20 mm	35 mm	6 mm	3,300 rpm	400 mm/min	800 rpm	1,000 mm/min	060 3560 0800
M10	1.5 mm	99 mm	22 mm	45 mm	7 mm	2,600 rpm	400 mm/min	700 rpm	1,050 mm/min	060 3560 1000

## 1.3 | THREADS

### Friction drill, long/flat, for aluminium

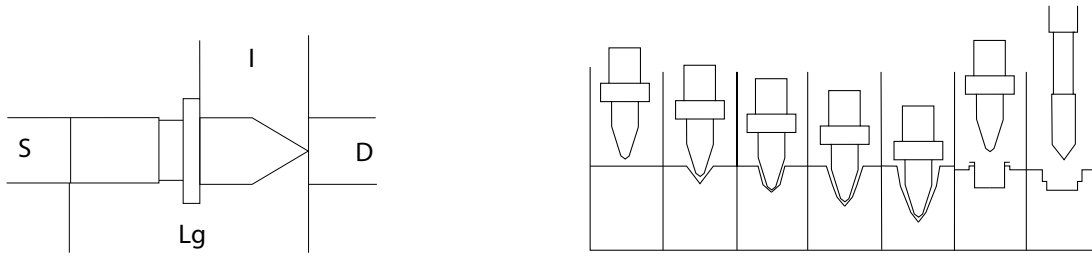

### Centerdrill

for	ALU	D	Lg	I	S					Order no.
M4	< 2 mm	3.6 mm	30 mm	10.3 mm	6 mm	3,900 rpm	0-2 mm	200 mm/min	20 %	060 3055 0012
							2-8mm	500 mm/min	100 %	
							8-10,3mm	1,000 mm/min	200 %	
M5	< 2.5 mm	4.5 mm	35 mm	11.8 mm	6 mm	3,750 rpm	0-2 mm	200 mm/min	20 %	060 3055 0013
							2-9 mm	500 mm/min	100 %	
							9-11.8 mm	1,000 mm/min	200 %	
M6	< 3 mm	5.4 mm	41 mm	14 mm	8 mm	3,600 rpm	0-3 mm	200 mm/min	20 %	060 3055 0014
							3-11 mm	500 mm/min	100 %	
							11-13.8 mm	1,000 mm/min	200 %	
M8	< 3 mm	7.3 mm	49 mm	18.2 mm	8 mm	3,300 rpm	0-4 mm	200 mm/min	20 %	060 3055 0015
							4- 15 mm	500 mm/min	100 %	
							15- 18.1 mm	1,000 mm/min	200 %	
M10	< 3 mm	9.2 mm	53 mm	22.5 mm	10 mm	3,000 rpm	0 - 4 mm	200 mm/min	20 %	060 3055 0016
							4- 18 mm	500 mm/min	100 %	
							18- 22.5 mm	1,000 mm/min	200 %	

### 1.3 | THREADS

#### Aludrill friction drill for aluminium

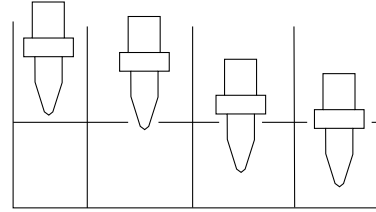
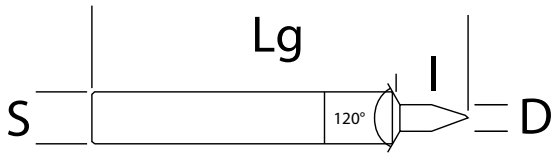

#### Aludrill 120°

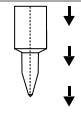
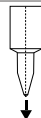
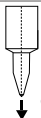
for	ALU	D	Lg	l	S					Order no.
M4	< 2 mm	3.6 mm	72 mm	10 mm	8 mm	6,000 rpm	0-2 mm	400 mm/min	20 %	060 3055 0048
							2-8 mm		100 %	
							8-10 mm		200 %	
M5	< 2.5 mm	4.3 mm	72 mm	11 mm	10 mm	5,500 rpm	0-2 mm	400 mm/min	20 %	060 3055 0049
							2-9 mm		100 %	
							9-11 mm		200 %	
M6	< 3 mm	5.2 mm	72 mm	14 mm	10 mm	5,000 rpm	0-2 mm	400 mm/min	20 %	060 3055 0050
							2-12 mm		100 %	
							12-14 mm		200 %	
M8	< 3 mm	7.1 mm	72 mm	18.2 mm	12 mm	4,500 rpm	0-2 mm	400 mm/min	20 %	060 3055 0051
							2- 16 mm		100 %	
							16- 18.2 mm		200 %	

### 1.3 | THREADS

#### Thread former for aluminium

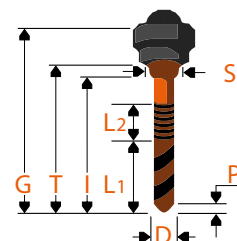
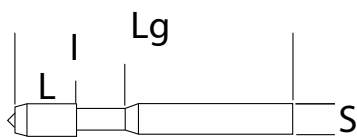

Thread		Lg	I	S				Order no.
M4	0.7 mm	63 mm	21 mm	4.5 mm	1,100 rpm	800 mm/min		060 3599 0006
					700 rpm	500 mm/min	alternative	
M5	0.8 mm	70 mm	25 mm	6 mm	1,000 rpm	800 mm/min		060 3599 0007
					630 rpm	500 mm/min	alternative	
M6	1 mm	80 mm	30 mm	6 mm	800 rpm	800 mm/min		060 3599 0008
					500 rpm	500 mm/min	alternative	
M8	1.25 mm	90 mm	35 mm	8 mm	640 rpm	800 mm/min		060 3599 0009
					800 rpm	500 mm/min	alternative	
M10	1.5 mm	100 mm	39 mm	10 mm	530 rpm	800 mm/min		060 3599 0010
					350 rpm	500 mm/min	alternative	

#### Solid carbide thread milling cutter for aluminium

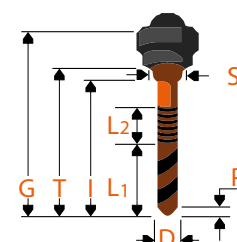
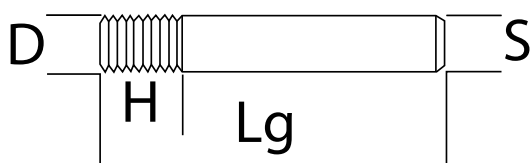

Thread	D		H (L1)	Lg	S	Z			Order no.
M4	2.6 mm	0.7 mm	6.3 mm	38 mm	3 mm	3	16,000 rpm	500 mm/min	060 3599 0002
M5	3.6 mm	0.8 mm	8 mm	42 mm	4 mm	3	11,500 rpm	500 mm/min	150 3732 00
M6	4 mm	1 mm	9 mm	57 mm	6 mm	3	10,000 rpm	500 mm/min	150 3732 01
M8	5 mm	1.25 mm	12.5 mm	57 mm	6 mm	3	7,000 rpm	500 mm/min	150 3732 02
M10	6 mm	1.5 mm	15 mm	57 mm	6 mm	5	7,000 rpm	700 mm/min	060 3599 0003
M12	6 mm	1.75 mm	19.2 mm	63 mm	8 mm	5	7,000 rpm	700 mm/min	060 3599 0004



# 1.4 | SAWING, NOTCHING

## Disc milling cutter for aluminium

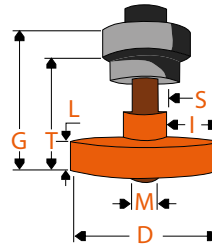
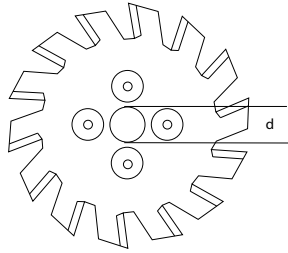

D	L	I	d	Z				Order no.
92 mm	3 mm	25 mm	16 mm	14	6,000 rpm	1,000 mm/min		060 4069 0020
					6,000 rpm	1,500 mm/min	alternative	
92 mm	4 mm	25 mm	16 mm	14	6,000 rpm	1,000 mm/min		060 4069 0039
					6,000 rpm	1,500 mm/min	alternative	
92 mm	5 mm	25 mm	16 mm	14	6,000 rpm	1,000 mm/min		060 4069 0023
					6,000 rpm	1,500 mm/min	alternative	
92 mm	6 mm	25 mm	16 mm	14	6,000 rpm	1,000 mm/min		150 3795 00
					6,000 rpm	1,500 mm/min	alternative	
120 mm	6 mm	39 mm	16 mm	18	6,000 rpm	1,000 mm/min		631 3795 07
					6,000 rpm	1,500 mm/min	alternative	
92 mm	10 mm	25 mm	16 mm	14	6,000 rpm	1,000 mm/min		150 3795 02
					6,000 rpm	1,500 mm/min	alternative	
100 mm	10 mm	29 mm	16 mm	14	6,000 rpm	1,000 mm/min		150 3795 04
					6,000 rpm	1,500 mm/min	alternative	
92 mm	15 mm	25 mm	16 mm	14	6,000 rpm	1,000 mm/min		150 3795 01
					6,000 rpm	1,500 mm/min	alternative	
92 mm	20 mm	25 mm	16 mm	14	6,000 rpm	1,000 mm/min		060 4069 0031
					6,000 rpm	1,500 mm/min	alternative	
180 mm	3.0 mm		20 mm	34	6,000 rpm	1,500 mm/min		150 3113 08
180 mm	3.5 mm		20 mm	34	6,000 rpm	1,500 mm/min		150 3113 02

The feed rates can vary depending on the cutting depth  
If the cutting result is poor, the cut should be split

### Holder for disc milling cutters

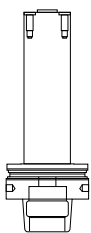

SBZ 122/140/150/151  
d = 16 mm  
Order no.  
136 3508 23

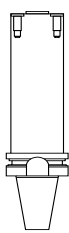

SBZ 130/131  
d = 16 mm  
Order no.  
130 3508 20



SBZ 122/140/150/151  
d = 20 mm, L = 155 mm  
Order no.  
136 3508 21



SBZ 122/75  
d = 20 mm, L = 100 mm  
Order no.  
136 3508 34



SBZ 122/75  
d = 16 mm, L = 95 mm  
Order no.  
136 3508 38

### Replacement screws 10.9



Cheese-head screw M6x18  
Order no. 150 8132 13



Countersunk screw M6x16  
Order no. 150 8135 01

# 1.4 | SAWING, NOTCHING

## Saw blades for aluminium

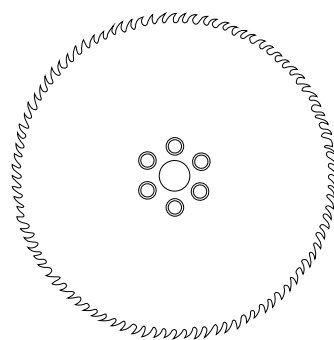

Type A

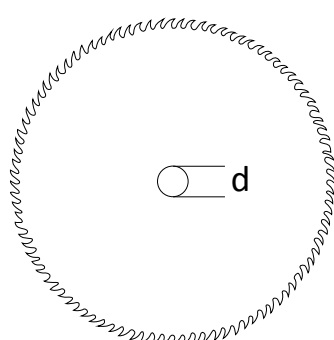

Type B

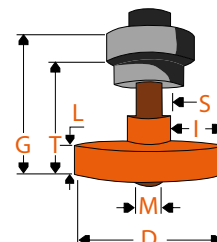

ALU	Type	D	L	l	d	Z				Order no.
<b>WD &lt; 3 mm</b>	<b>A</b>	<b>500 mm</b>	<b>4.6 mm</b>	<b>130 mm</b>	<b>32 mm</b>	<b>120</b>	<b>3,000 rpm</b>	<b>2,000 mm/min</b>		<b>151 3113 00</b>
WD > 3 mm							3,000 rpm	1,000 mm/min	alternative	<b>151 2076 00*</b> <b>151 2091 01**</b>
<b>WD &lt; X mm</b>	<b>A</b>	<b>500 mm</b>	<b>4.6 mm</b>	<b>130 mm</b>	<b>32 mm</b>	<b>96</b>	<b>3,000 rpm</b>	<b>1,500 mm/min</b>		<b>151 2091 03**</b>
WD > X mm							3,000 rpm	800 mm/min	alternative	<b>151 2076 07*</b>
<b>WD &lt; 5 mm</b>	<b>A</b>	<b>500 mm</b>	<b>4.6 mm</b>	<b>130 mm</b>	<b>32 mm</b>	<b>60</b>	<b>3,000 rpm</b>	<b>1,500 mm/min</b>		<b>151 3113 05</b>
WD > 5 mm							3,000 rpm	800 mm/min	alternative	<b>151 2076 02*</b> <b>151 2091 03**</b>
<b>WD &lt; 3 mm</b>	<b>A</b>	<b>400 mm</b>	<b>4.6 mm</b>	<b>90 mm</b>	<b>32 mm</b>	<b>96</b>	<b>4,000 rpm</b>	<b>2,000 mm/min</b>		<b>151 2091 02**</b>
WD > 3 mm							4,000 rpm	1,000 mm/min	alternative	<b>151 2076 01*</b>
<b>WD &lt; 3 mm</b>	<b>B</b>	<b>400 mm</b>	<b>4.6 mm</b>	<b>90 mm</b>	<b>32 mm</b>	<b>96</b>	<b>4,000 rpm</b>	<b>2,000 mm/min</b>		<b>151 2076 01</b>
WD > 3 mm							4,000 rpm	1,000 mm/min	alternative	
<b>WD &lt; 3 mm</b>	<b>B</b>	<b>400 mm</b>	<b>3.8 mm</b>	<b>90 mm</b>	<b>32 mm</b>	<b>96</b>	<b>4,000 rpm</b>	<b>2,000 mm/min</b>		<b>150 3113 01</b>
WD > 3 mm							4,000 rpm	1,000 mm/min	alternative	
<b>WD &lt; 3 mm</b>	<b>B</b>	<b>300 mm</b>	<b>3.2 mm</b>	<b>105 mm</b>	<b>32 mm</b>	<b>100</b>	<b>5,000 rpm</b>	<b>1,500 mm/min</b>		<b>131 3113 03</b>
WD > 3 mm							5,000 rpm	1,000 mm/min	alternative	
<b>WD &lt; 3 mm</b>	<b>B</b>	<b>300 mm</b>	<b>3.2 mm</b>	<b>105 mm</b>	<b>32 mm</b>	<b>76</b>	<b>5,000 rpm</b>	<b>1,500 mm/min</b>		<b>131 3113 04</b>
WD > 3 mm							5,000 rpm	1,000 mm/min	alternative	
<b>WD &lt; 3 mm</b>	<b>B</b>	<b>254 mm</b>	<b>3.4 mm</b>	<b>85 mm</b>	<b>32 mm</b>	<b>68</b>	<b>5,000 rpm</b>	<b>1,500 mm/min</b>		<b>101 3113 00</b>
WD > 3 mm							5,000 rpm	1,000 mm/min	alternative	

The feed rates can vary depending on the amount of material to be removed

\* Saw blade with countersunk screws    \*\* Saw blade with holder

## 1.5 | SPECIAL TOOLS

### Milling cutter with HM inserts

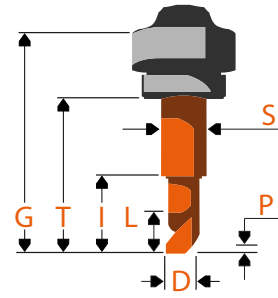
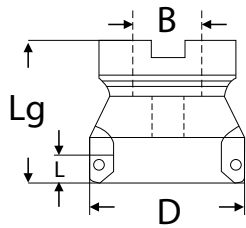

ALU	D	B	L	Lg	Z	X max	Step	$\alpha$	D max			Order - No.
<Si 0,5%	40 mm	16 mm	10 mm	50 mm	4	1,5 mm	7,5 mm	2,7°	70 mm	8000 rpm	3200 mm/min	189145
<Si 0,5%	50 mm	22 mm	10 mm	50 mm	4	1,5 mm	7,5 mm	2,2°	90 mm	6400 rpm	2570 mm/min	189146
<Si 0,5%	63 mm	22 mm	10 mm	50 mm	4	1,5 mm	7,5 mm	1,7°	116 mm	5000 rpm	2000 mm/min	189147
<Si 0,5%	80 mm	27 mm	10 mm	50 mm	4	1,5 mm	7,5 mm	1,2°	150 mm	4000 rpm	1600 mm/min	189148
>Si 0,5%	40 mm	16 mm	10 mm	50 mm	4	1,5 mm	7,5 mm	2,7°	70 mm	3200 rpm	1600 mm/min	189145
>Si 0,5%	50 mm	22 mm	10 mm	50 mm	4	1,5 mm	7,5 mm	2,2°	90 mm	2550 rpm	1300 mm/min	189146
>Si 0,5%	63 mm	22 mm	10 mm	50 mm	4	1,5 mm	7,5 mm	1,7°	116 mm	2020 rpm	1000 mm/min	189147
>Si 0,5%	80 mm	27 mm	10 mm	50 mm	4	1,5 mm	7,5 mm	1,2°	150 mm	1600 1rpm	800 mm/min	189148

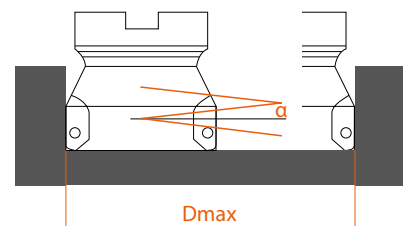
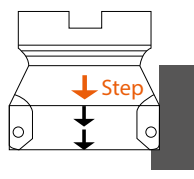
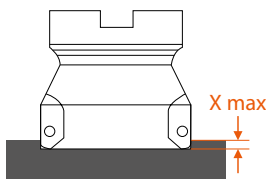

#### HM insert



HM insert type	Radius	Order no.
XDHT	0.4 mm	189149
XDHT	1.2 mm	1891410
XDHT	2.5 mm	1891411

#### Torx screwdriver



Item	Order no.
Torque handle 1.8 Nm	1891413
Interchangeable blade for torque handle	1891414
Torx screw M2.5	1891412

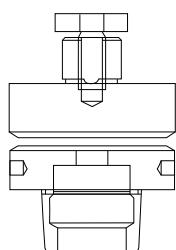

#### Milling arbor

Item	Order no.
HSK-F63 milling arbor d = 16 mm	upon request
HSK-F63 milling arbor d = 22 mm	136 3508 04
HSK-F63 milling arbor d = 27 mm	136 3508 02

## 1.5 | SPECIAL TOOLS

### HSS step drill, short, for aluminium

- Step drill DIN 1897 with 180° countersink angle for through holes

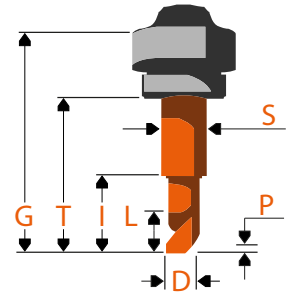
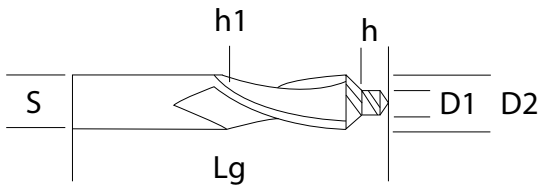

for	D1	D2	h(L)	Lg	h1	T	S	Z			Order no.
M3	3.4 mm	6 mm	9 mm	45 mm	20 mm	30 mm	6 mm	2	3,500 rpm	400 mm/min	060 3032 0071
M4	4.5 mm	8 mm	11 mm	50 mm	24 mm	30 mm	8 mm	2	3,000 rpm	400 mm/min	060 3032 0072
M5	5.5 mm	10 mm	13 mm	55 mm	28 mm	30 mm	10 mm	2	2,500 rpm	400 mm/min	060 3032 0073
M6	6.6 mm	11 mm	15 mm	63 mm	31 mm	30 mm	11 mm	2	3,500 rpm	400 mm/min	060 3032 0074
M8	9 mm	15 mm	19 mm	100 mm	40 mm	30 mm	12.5 mm	2	2,500 rpm	400 mm/min	060 3032 0075
M10	11 mm	18 mm	23 mm	110 mm	47 mm	30 mm	12.5 mm	2	2,000 rpm	400 mm/min	060 3032 0076

### Multifunctional milling cutter, 90°, for aluminium

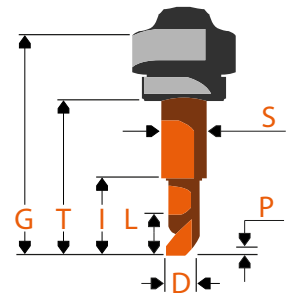
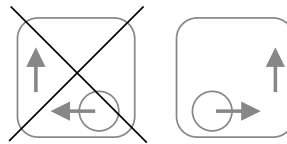
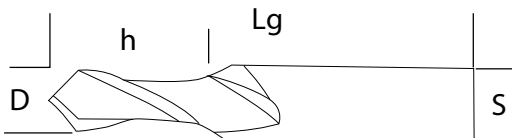

ALU	D	h(L)	Lg	T	S	Z				Order no.
< 2 mm	6 mm	12 mm	60 mm	35 mm	8 mm	2	18,000 rpm	800 mm/min	300 mm/min	060 4099 0165
								600 mm/min	280 mm/min	alternative
								400 mm/min	250 mm/min	alternative
< 2 mm	8 mm	16 mm	70 mm	40 mm	10 mm	2	24,000 rpm	1,200 mm/min	350 mm/min	060 4099 0166
								800 mm/min	300 mm/min	alternative
								600 mm/min	250 mm/min	alternative
< 3 mm	10 mm	18 mm	70 mm	40 mm	12 mm	2	15,000 rpm	800 mm/min	350 mm/min	060 4099 0167
								600 mm/min	250 mm/min	alternative
< 3 mm	12 mm	20 mm	70 mm	40 mm	12 mm	2	18,000 rpm	1,200 mm/min	350 mm/min	060 4099 0168
								600 mm/min	250 mm/min	alternative
< 4 mm	16 mm	26 mm	80 mm	50 mm	16 mm	2	18,000 rpm	1,500 mm/min	300 mm/min	060 4099 0169
								1,000 mm/min	200 mm/min	alternative

## 1.5 | SPECIAL TOOLS

### HM milling cutter for aluminium with AL-LF coating

- Significantly reduced friction
- As a result, almost no spray oil is necessary for maximum machining quality.

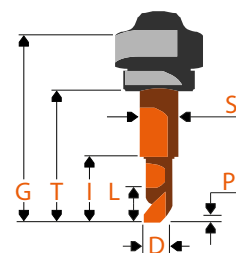
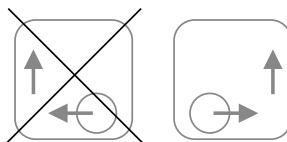
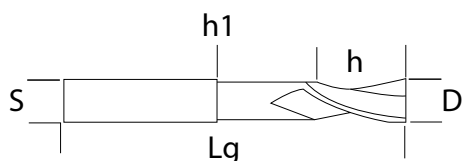

ALU	D	h(L)	Lg	h1(l)	T	S	Z					Order no.				
< 2 mm	4 mm	10 mm	70 mm		40 mm	8 mm	1	12,000 rpm	500 mm/min	200 mm/min		140 3990 0104				
											17,500 rpm		700 mm/min	250 mm/min	alternative	
< 3 mm	5 mm	16 mm	70 mm		40 mm	8 mm	1	8,000 rpm	500 mm/min	250 mm/min		140 3990 0105				
											9,600 rpm		600 mm/min	280 mm/min	alternative	
											16,000 rpm		900 mm/min	300 mm/min	alternative	
< 2.5 mm	5 mm	20 mm	80 mm	25 mm	50 mm	8 mm	1	7,500 rpm	550 mm/min	550 mm/min		140 3990 1105				
< 2 mm								16,000 rpm	800 mm/min	280 mm/min	alternative					
< 2 mm								12,000 rpm	600 mm/min	250 mm/min	alternative					
< 2 mm	5 mm	10 mm	80 mm	40 mm	50 mm	8 mm	1	7,500 rpm	400 mm/min	220 mm/min		140 3990 2105				
											12,000 rpm		500 mm/min	280 mm/min	alternative	
< 2 mm	8 mm	22 mm	80 mm	40 mm	42 mm	8 mm	1	7,000 rpm	500 mm/min	200 mm/min		140 3990 1108				
											50 mm		12,000 rpm	800 mm/min	250 mm/min	alternative
											50 mm		20,000 rpm	1,200 mm/min	300 mm/min	alternative
< 3 mm	10 mm	12 mm	90 mm	60 mm	65 mm	10 mm	2	6,000 rpm	600 mm/min	200 mm/min		140 3990 1210				
< 2 mm								15,000 rpm	800 mm/min	250 mm/min	alternative					
< 4 mm*	12 mm	12 mm	100 mm	60 mm	65 mm	12	2	16,000 rpm	1,000 mm/min	300 mm/min		140 3990 1212				
											12,000 rpm		800 mm/min	250 mm/min	alternative	
< 4 mm*	16 mm	32 mm	102 mm	60 mm	70 mm	16	3	14,000 rpm	2,100 mm/min	250 mm/min		140 3990 1316				

\*Use ER 32 collet

## 1.5 | SPECIAL TOOLS

### Milling cutter diamond-tipped with PCD

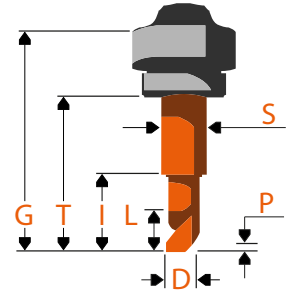
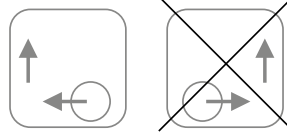
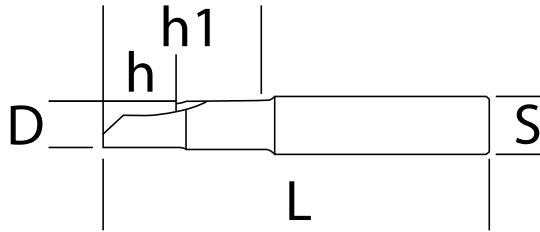

ALU	D	h(L)	Lg	h1(l)	T	S	Z					Order no.
2 mm	10 mm	15 mm	80 mm	32 mm	40 mm	12	2	16,000 rpm	4,000 mm/min	300 mm/min		060 4079 1802
3 mm								14,000 rpm	4,000 mm/min	300 mm/min	alternative	

Dry milling tested on material EN AW-6060 T6.

## 2.1 | DRILLING

HSS twist drill, DIN 338, 5xD, type N for steel

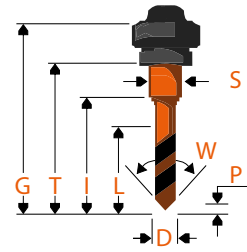
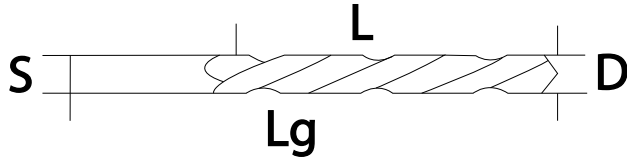

St37	D	L	Lg	S	Z			Order no.
< 2 mm	2.5 mm	30 mm	57 mm	2.5 mm	2	3,180 rpm	220 mm/min	060 3000 0250
< 3 mm	3 mm	33 mm	61 mm	3 mm	2	2,500 rpm	230 mm/min	060 3000 0300
< 3 mm	3.3 mm	33 mm	65 mm	3.3 mm	2	2,400 rpm	240 mm/min	060 3000 0330
< 4 mm	4.2 mm	43 mm	75 mm	4.2 mm	2	1,900 rpm	220 mm/min	060 3000 0420
< 5 mm	5 mm	52 mm	86 mm	5 mm	2	1,600 rpm	190 mm/min	060 3000 0500
< 6 mm	6 mm	57 mm	93 mm	6 mm	2	1,320 rpm	170 mm/min	060 3000 0600
< 6 mm	6.8 mm	69 mm	109 mm	6.8 mm	2	1,160 rpm	170 mm/min	060 3000 0680
< 8 mm	8 mm	75 mm	117 mm	8 mm	2	1,050 rpm	160 mm/min	060 3000 0800
< 8 mm	8.5 mm	75 mm	117 mm	8.5 mm	2	940 rpm	150 mm/min	060 3000 0850
< 8 mm	10 mm	87 mm	133 mm	10 mm	2	800 rpm	150 mm/min	060 3000 1000
< 8 mm	11 mm	94 mm	142 mm	11 mm	2	730 rpm	140 mm/min	060 3000 1100
< 8 mm	12 mm	101 mm	151 mm	12 mm	2	660 rpm	130 mm/min	060 3000 1200

Tested materials: St37

## 2.1 | DRILLING

HSS twist drill, DIN 338, 5xD, type Uni with TiN coating for steel

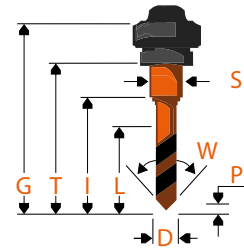
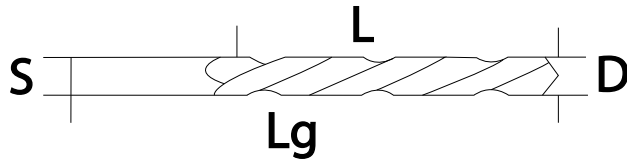

St37	D	L	Lg	S	Z			Order no.
< 2 mm	2.5 mm	30 mm	57 mm	2.5 mm	2	5,100 rpm	350 mm/min	060 3090 0250
< 3 mm	3 mm	33 mm	61 mm	3 mm	2	4,250 rpm	350 mm/min	060 3090 0300
< 3 mm	3.2 mm	36 mm	65 mm	3.2 mm	2	4,000 rpm	320 mm/min	060 3090 0320
< 3 mm	3.3 mm	36 mm	65 mm	3.3 mm	2	3,860 rpm	320 mm/min	060 3090 0330
< 3 mm	3.5 mm	39 mm	70 mm	3.5 mm	2	3,640 rpm	320 mm/min	060 3090 0350
< 4 mm	4 mm	43 mm	75 mm	4 mm	2	3,190 rpm	310 mm/min	060 3090 0400
< 4 mm	4.2 mm	43 mm	75 mm	4.2 mm	2	3,030 rpm	310 mm/min	060 3090 0420
< 4 mm	4.5 mm	47 mm	75 mm	4.5 mm	2	2,830 rpm	310 mm/min	060 3090 0450
< 5 mm	5 mm	52 mm	86 mm	5 mm	2	2,550 rpm	300 mm/min	060 3090 0500
< 5 mm	5.5 mm	57 mm	93 mm	5.5 mm	2	2,320 rpm	290 mm/min	060 3090 0550
< 6 mm	6 mm	57 mm	93 mm	6 mm	2	2,200 rpm	270 mm/min	060 3090 0600
< 6 mm	6.5 mm	63 mm	101 mm	6.5 mm	2	1,960 rpm	260 mm/min	060 3090 0650
< 6 mm	6.8 mm	69 mm	109 mm	6.8 mm	2	1,870 rpm	260 mm/min	060 3090 0680
< 7 mm	7 mm	69 mm	109 mm	7 mm	2	1,700 rpm	250 mm/min	060 3090 0700
< 8 mm	8 mm	75 mm	117 mm	8 mm	2	1,600 rpm	250 mm/min	060 3090 0800
< 8 mm	8.5 mm	75 mm	117 mm	8.5 mm	2	1,500 rpm	250 mm/min	060 3090 0850
< 8 mm	9 mm	81 mm	125 mm	9 mm	2	1,410 rpm	250 mm/min	060 3090 0900
< 8 mm	10 mm	87 mm	133 mm	10 mm	2	1,270 rpm	250 mm/min	060 3090 1000
< 8 mm	10.5 mm	87 mm	133 mm	10.5 mm	2	1,200 rpm	240 mm/min	060 3090 1050
< 8 mm	11 mm	94 mm	142 mm	11 mm	2	1,150 rpm	210 mm/min	060 3090 1100
< 8 mm	12 mm	101 mm	151 mm	12 mm	2	1,060 rpm	200 mm/min	060 3090 1200
< 8 mm	13 mm	101 mm	151 mm	13 mm	2	980 rpm	200 mm/min	060 3090 1300
< 8 mm	14 mm	108 mm	160 mm	14 mm	2	910 rpm	200 mm/min	060 3090 1400



## 2.2 | MILLING

### Milling cutter for steel machining with coating

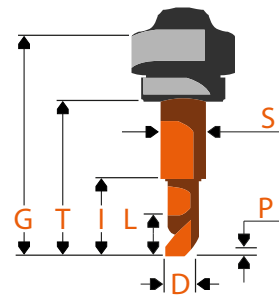
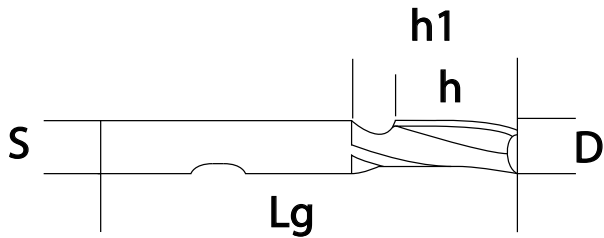

### Milling cutter made from PM (powder steel)

FE = St37	D	h(L)	Lg	h1(l)	T	S	Z					Order no.
FE < 3 mm	6 mm	13 mm	57 mm		25 mm	6 mm	4	2,150 rpm	220 mm/min	50 mm/min	PM	060 4030 0600
FE < 3 mm	8 mm	19 mm	69 mm	22 mm	30 mm	10 mm	4	3,000 rpm	300 mm/min	50 mm/min	PM	060 4030 0800
FE < 3 mm	8 mm	28 mm	78 mm	38 mm	40 mm	10 mm	4	3,000 rpm	300 mm/min	50 mm/min	PM	060 4032 0800
FE < 2 mm	8 mm	38 mm	88 mm	38 mm	50 mm	10 mm	4	3,000 rpm	250 mm/min	50 mm/min	Co5	060 4031 0800
FE < 3 mm	10 mm	22 mm	72 mm		35 mm	10 mm	4	1,290 rpm	220 mm/min	60 mm/min	PM	060 4030 1000
FE < 2 mm								2,500 rpm	350 mm/min	70 mm/min	alternative	
FE < 3 mm	12 mm	26 mm	83 mm		40 mm	12 mm	4	1,080 rpm	210 mm/min	60 mm/min	PM	060 4030 1200
FE < 2 mm								1,250 rpm	250 mm/min	70 mm/min	alternative	

### Solid carbide milling cutter

FE = St37	D	h(L)	Lg	T	S	Z					Order no.
FE < 2 mm	5 mm	8 mm	54 mm	25 mm	6 mm	2	9,600 rpm	500 mm/min	250 mm/min	HM	060 4099 0117
							6,000 rpm	350 mm/min	150 mm/min	alternative	
FE < 2 mm	6 mm	10 mm	54 mm	25 mm	6 mm	2	8,000 rpm	600 mm/min	230 mm/min	HM	060 4099 0118
							11,500 rpm	800 mm/min	300 mm/min	alternative	
							6,000 rpm	400 mm/min	150 mm/min	alternative	
FE < 3 mm	8 mm	12 mm	59 mm	30 mm	8 mm	2	6,000 rpm	550 mm/min	150 mm/min	HM	060 4099 0119
							8,500 rpm	800 mm/min	300 mm/min	alternative	
FE < 4 mm	10 mm	13 mm	67 mm	35 mm	10 mm	2	6,000 rpm	650 mm/min	150 mm/min	HM	060 4099 0120

## 2.3 | THREADS

### Friction drill, long/flat, for steel

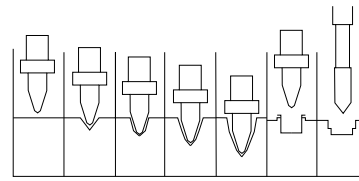
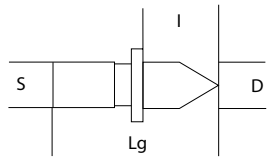

for	Steel	D	Lg	I	S					Order no.
							0-3 mm	70 mm/min	10 %	
<b>M4</b>	< 3 mm	3.6 mm	30 mm	10.3 mm	6 mm	2,600 rpm	3-8 mm	140 mm/min	20 %	<b>060 3055 0012</b>
							8-10.3 mm	700 mm/min	100 %	
<b>M5</b>	< 3 mm	4.5 mm	35 mm	11.8 mm	6 mm	2,500 rpm	0-3 mm	70 mm/min	10 %	<b>060 3055 0013</b>
							3-9 mm	140 mm/min	20 %	
							9-11.8 mm	700 mm/min	100 %	
<b>M6</b>	< 3.5 mm	5.4 mm	41 mm	13.8 mm	8 mm	2,400 rpm	0-4 mm	70 mm/min	10 %	<b>060 3055 0014</b>
							4-10 mm	140 mm/min	20 %	
							11-13.8 mm	700 mm/min	100 %	
<b>M8</b>	< 4 mm	7.3 mm	49 mm	18.1 mm	8 mm	2,200 rpm	0-5 mm	70 mm/min	10 %	<b>060 3055 0015</b>
							5-16 mm	140 mm/min	20 %	
							16-18.1 mm	700 mm/min	100 %	

Spindle speed +/- 10 % depending on material quality and wall thickness.  
The machine must be suitable for these tools.

### Thread former for steel

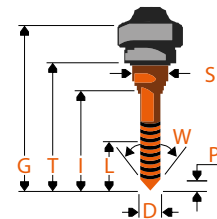
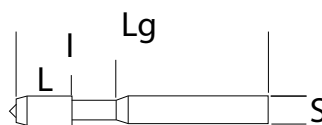

Thread		Lg	I	S			Order no.
<b>M4</b>	0.7 mm	63 mm	21 mm	4.5 mm	700 rpm	500 mm/min	<b>060 3599 0006</b>
					1,100 rpm	800 mm/min	alternative
<b>M5</b>	0.8 mm	70 mm	25 mm	6 mm	630 rpm	500 mm/min	<b>060 3599 0007</b>
					1,000 rpm	800 mm/min	alternative
<b>M6</b>	1 mm	80 mm	30 mm	6 mm	500 rpm	500 mm/min	<b>060 3599 0008</b>
					800 rpm	800 mm/min	alternative
<b>M8</b>	1.25 mm	90 mm	35 mm	8 mm	400 rpm	500 mm/min	<b>060 3599 0009</b>
					640 rpm	800 mm/min	alternative
<b>M10</b>	1.5 mm	100 mm	39 mm	10 mm	350 rpm	500 mm/min	<b>060 3599 0010</b>
					530 rpm	800 mm/min	alternative

## 2.4 | SAWING

### Saw blades for St37 steel

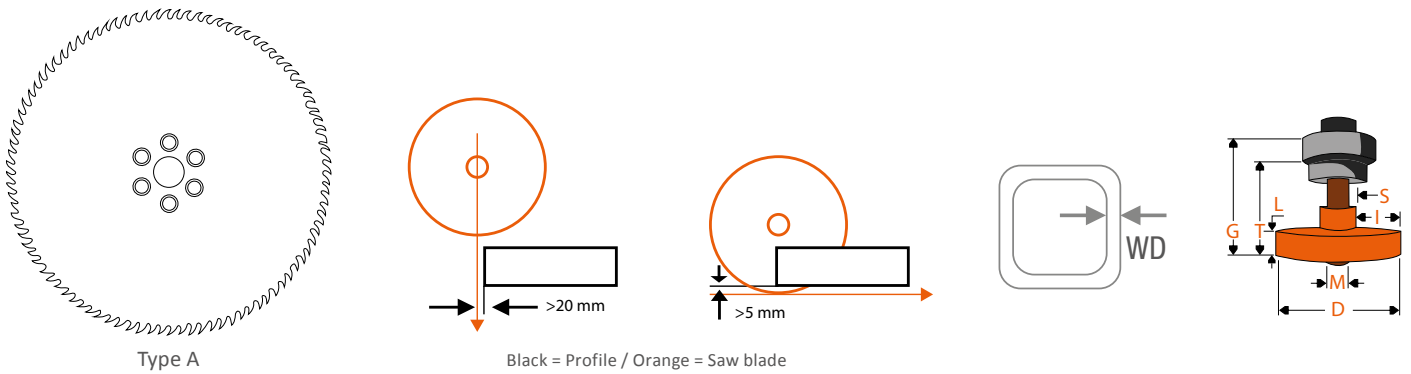

ST37	Type	D	L	l	d	Z				Order no.
WD < 2 mm	B	250 mm	2 mm	130 mm	32 mm	60	1,600 rpm	800 mm/min		131 3113 08
							1,600 rpm	1,000 mm/min	alternative	
WD < 2 mm	A	400 mm	2.2 mm	130 mm	32 mm	100	1,300 rpm	1,300 mm/min		151 3113 07
							1,000 rpm	1,000 mm/min	alternative	

The feed rates can vary depending on the amount of material to be removed

## 3.1 | DRILLING

### HSS twist drill, DIN 338, 5xD, type Uni with TiN coating for stainless steel/Inox

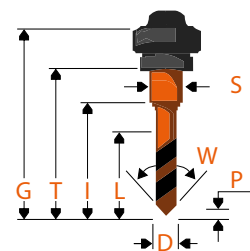
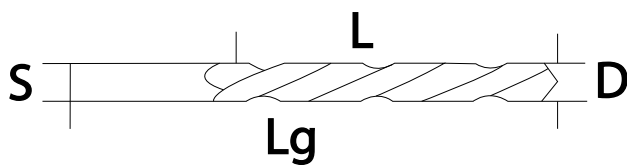



INOX 1.4301	D	L	Lg	S	Z				Order no.
< 2 mm	2.5 mm	30 mm	57 mm	2.5 mm	2	1,650 rpm	66 mm/min		060 3090 0250
						1,500 rpm	50 mm/min	alternative	
< 2.5 mm	3 mm	33 mm	61 mm	3 mm	2	1,380 rpm	69 mm/min		060 3090 0300
						1,250 rpm	52 mm/min	alternative	
< 2.5 mm	3.2 mm	36 mm	65 mm	3.2 mm	2	1,300 rpm	67 mm/min		060 3090 0320
						1,160 rpm	50 mm/min	alternative	

Continues on next page

## HSS twist drill, DIN 338, 5xD, type Uni with TiN coating for stainless steel/Inox

Continued from previous page

INOX 1.4301	D	L	Lg	S	Z				Order no.
< 2.5 mm	3.3 mm	39 mm	65 mm	3.3 mm	2	1,250 rpm	66 mm/min		060 3090 0330
						1,130 rpm	50 mm/min	alternative	
< 3 mm	3.5 mm	43 mm	70 mm	3.5 mm	2	1,180 rpm	62 mm/min		060 3090 0350
						1,060 rpm	49 mm/min	alternative	
						930 rpm/min	47 mm/min	alternative	
< 3 mm	4.0 mm	43 mm	75 mm	4.0 mm	2	1,000 rpm	61 mm/min		060 3090 0400
						890 rpm	46 mm/min	alternative	
< 3 mm	4.2 mm	43 mm	75 mm	4.2 mm	2	985 rpm	61 mm/min		060 3090 0420
						890 rpm	46 mm/min	alternative	
< 4 mm	4.5 mm	47 mm	75 mm	4.5 mm	2	920 rpm	60 mm/min		060 3090 0450
						830 rpm	45 mm/min	alternative	
< 4 mm	5 mm	52 mm	86 mm	5 mm	2	830 rpm	58 mm/min		060 3090 0500
						750 rpm	43 mm/min	alternative	
< 4 mm	5.5 mm	57 mm	93 mm	5.5 mm	2	755 rpm	56 mm/min		060 3090 0550
						680 rpm	42 mm/min	alternative	
< 5 mm	6 mm	57 mm	93 mm	6 mm	2	690 rpm	55 mm/min		060 3090 0600
						620 rpm	41 mm/min	alternative	
< 5 mm	6.5 mm	63 mm	101 mm	6.5 mm	2	640 rpm	54 mm/min		060 3090 0650
						575 rpm	41 mm/min	alternative	
< 5 mm	6.8 mm	69 mm	109 mm	6.8 mm	2	610 rpm	55 mm/min		060 3090 0680
						540 rpm	41 mm/min	alternative	
< 5 mm	7 mm	69 mm	109 mm	7 mm	2	590 rpm	53 mm/min		060 3090 0700
						530 rpm	40 mm/min	alternative	
< 5 mm	8 mm	75 mm	117 mm	8 mm	2	520 rpm	52 mm/min		060 3090 0800
						470 rpm	39 mm/min	alternative	
< 5 mm	8.5 mm	75 mm	117 mm	8.5 mm	2	485 rpm	51 mm/min		060 3090 0850
						440 rpm	38 mm/min	alternative	
< 5 mm	9 mm	81 mm	125 mm	9 mm	2	460 rpm	51 mm/min		060 3090 0900
						415 rpm	38 mm/min	alternative	
< 5 mm	10 mm	87 mm	133 mm	10 mm	2	415 rpm	50 mm/min		060 3090 1000
						375 rpm	37 mm/min	alternative	

Tested INOX materials: 304, 316, 316L, V2A, 1.4301 (drill type N is not suitable)

### 3.2 | MILLING

#### Milling cutter for stainless steel machining with coating

Milling cutter made from PM (powder steel)

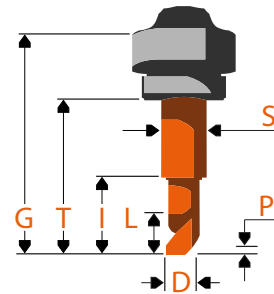
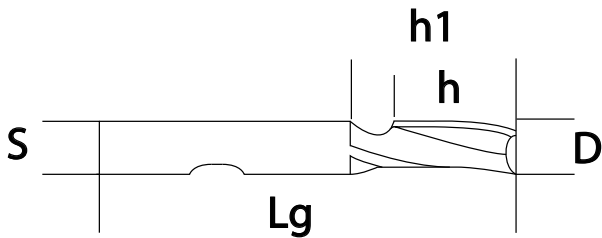

INOX	D	h(L)	Lg	h1(l)	T	S	Z					Order no.
< 2 mm	6 mm	13 mm	57 mm		25 mm	6 mm	4	1,350 rpm	80 mm/min	30 mm/min	PM	060 4030 0600
								950 rpm	60 mm/min	20 mm/min	alternative	
								1,750 rpm	100 mm/min	40 mm/min	alternative	
< 2 mm	8 mm	19 mm	69 mm	22 mm	30 mm	10 mm	4	850 rpm	100 mm/min	30 mm/min	PM	060 4030 0800
< 3 mm								600 rpm	70 mm/min	20 mm/min	alternative	
< 3 mm								1,080 rpm	130 mm/min	40 mm/min	alternative	
< 2 mm	8 mm	28 mm	78 mm	38 mm	40 mm	10 mm	4	850 rpm	100 mm/min	30 mm/min	PM	060 4032 0800
< 3 mm								600 rpm	70 mm/min	20 mm/min	alternative	
< 3 mm								1,100 rpm	130 mm/min	40 mm/min	alternative	
< 2 mm	10 mm	22 mm	72 mm		35 mm	10 mm	4	780 rpm	100 mm/min	30 mm/min	PM	060 4030 1000
< 3 mm								550 rpm	70 mm/min	20 mm/min	alternative	
< 3 mm								1,080 rpm	120 mm/min	30 mm/min	alternative	

Tested INOX materials: 304, 316, 316L, V2A, 1.4301, V4A with water cooling for PM

#### Solid carbide milling cutter

INOX	D	h(L)	Lg	T	S	Z					Order no.	
< 3 mm	5 mm	8 mm	54 mm	25 mm	6 mm	2	6,000 rpm	250 mm/min	130 mm/min	HM	060 4099 0117	
								12,000 rpm	500 mm/min	250 mm/min	alternative	
< 3 mm	6 mm	10 mm	54 mm	25 mm	6 mm	2	5,000 rpm	300 mm/min	150 mm/min	HM	060 4099 0118	
								10,000 rpm	550 mm/min	200 mm/min	alternative	
< 3 mm	8 mm	12 mm	59 mm	30 mm	8 mm	2	4,000 rpm	250 mm/min	125 mm/min	HM	060 4099 0199	
								8,000 rpm	500 mm/min	200 mm/min	alternative	
< 4 mm	10 mm	13 mm	67 mm	35 mm	10 mm	2	3,000 rpm	250 mm/min	125 mm/min	HM	060 4099 0120	
								6,000 rpm	500 mm/min	200 mm/min	alternative	

Tested INOX materials: 304, 316, 316L, V2A, 1.4301 for HM

### 3.3 | THREADS

#### HSS screw tap for stainless steel/Inox

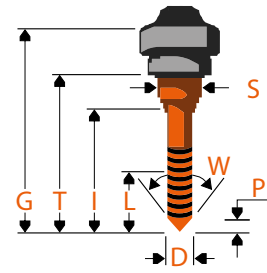
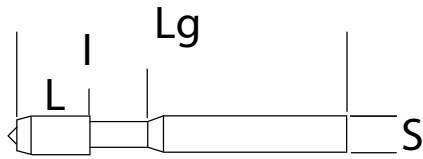



Thread		TL	I	S	L			Order no.
M3	0.5 mm	56 mm	18 mm	3.5 mm	6 mm	550 rpm	275 mm/min	060 3502 0300
M4	0.7 mm	63 mm	21 mm	4.5 mm	7 mm	400 rpm	280 mm/min	060 3508 0400
M5	0.8 mm	70 mm	25 mm	6 mm	8 mm	350 rpm	280 mm/min	060 3508 0500
M6	1 mm	80 mm	30 mm	6 mm	10 mm	300 rpm	300 mm/min	060 3508 0600
M8	1.25 mm	90 mm	35 mm	8 mm	14 mm	200 rpm	250 mm/min	060 3508 0800
M10	1.5 mm	100 mm	39 mm	10 mm	16 mm	160 rpm	240 mm/min	060 3508 1000

Tested INOX materials: 304, 316, 316L, V2A, 1.4301

### 4.1 | DRILLING

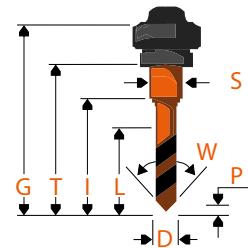
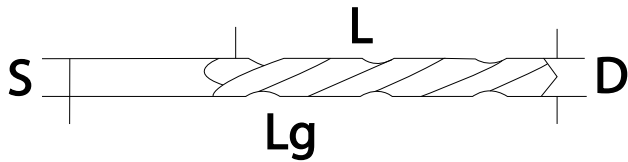
HSS twist drill, DIN 338, 5xD, type Uni with TiN coating for PVC



PVC	D	L	Lg	S	z			Order no.
WD < 3 mm	2.5 mm	30 mm	57 mm	2.5 mm	2	10,000 rpm	1,000 mm/min	060 3090 0250
WD < 3 mm	3 mm	33 mm	61 mm	3 mm	2	8,500 rpm	1,100 mm/min	060 3090 0300
WD < 3 mm	3.2 mm	36 mm	65 mm	3.2 mm	2	8,000 rpm	1,100 mm/min	060 3090 0320
WD < 3 mm	3.3 mm	36 mm	65 mm	3.3 mm	2	7,800 rpm	1,100 mm/min	060 3090 0330
WD < 3 mm	3.5 mm	39 mm	70 mm	3.5 mm	2	7,300 rpm	1,050 mm/min	060 3090 0350
WD < 3 mm	4 mm	43 mm	75 mm	4 mm	2	6,400 rpm	1,000 mm/min	060 3090 0400
WD < 4 mm	4.2 mm	43 mm	75 mm	4.2 mm	2	6,000 rpm	1,000 mm/min	060 3090 0420
WD < 4 mm	4.5 mm	47 mm	75 mm	4.5 mm	2	5,700 rpm	950 mm/min	060 3090 0450
WD < 4 mm	5 mm	52 mm	86 mm	5 mm	2	5,100 rpm	900 mm/min	060 3090 0500
WD < 4 mm	5.5 mm	57 mm	93 mm	5.5 mm	2	4,630 rpm	870 mm/min	060 3090 0550
WD < 4 mm	6 mm	57 mm	93 mm	6 mm	2	4,250 rpm	830 mm/min	060 3090 0600
WD < 4 mm	6.5 mm	63 mm	101 mm	6.5 mm	2	3,900 rpm	800 mm/min	060 3090 0650
WD < 4 mm	6.8 mm	69 mm	109 mm	6.8 mm	2	3,750 rpm	800 mm/min	060 3090 0680
WD < 4 mm	7 mm	69 mm	109 mm	7 mm	2	3,640 rpm	800 mm/min	060 3090 0700
WD < 5 mm	8 mm	75 mm	117 mm	8 mm	2	3,200 rpm	780 mm/min	060 3090 0800
WD < 5 mm	8.5 mm	75 mm	117 mm	8.5 mm	2	3,000 rpm	780 mm/min	060 3090 0850
WD < 5 mm	9 mm	81 mm	125 mm	9 mm	2	2,830 rpm	760 mm/min	060 3090 0900
WD < 5 mm	10 mm	87 mm	133 mm	10 mm	2	2,550 rpm	740 mm/min	060 3090 1000
WD < 5 mm	10.5 mm	87 mm	133 mm	10.5 mm	2	2,430 rpm	740 mm/min	060 3090 1050
WD < 5 mm	11 mm	94 mm	142 mm	11 mm	2	2,300 rpm	720 mm/min	060 3090 1100
WD < 5 mm	12 mm	101 mm	151 mm	12 mm	2	2,120 rpm	700 mm/min	060 3090 1200
WD < 5 mm	13 mm	101 mm	151 mm	13 mm	2	1,960 rpm	650 mm/min	060 3090 1300
WD < 5 mm	14 mm	108 mm	160 mm	14 mm	2	1,820 rpm	630 mm/min	060 3090 1400

## 4.2 | MILLING

### HM milling cutter for PVC

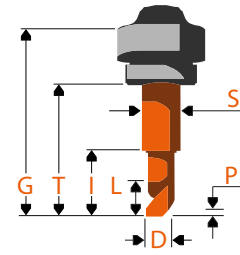
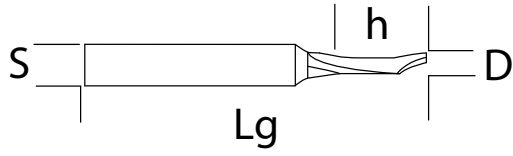

PVC	D	h(L)	Lg	T	S	Z					Order no.
< 3 mm	5 mm	40 mm	80 mm	50 mm	5 mm	1	18,000 rpm	800 mm/min	300 mm/min		610 3703 01
							12,000 rpm	600 mm/min	280 mm/min	alternative	
							8,000 rpm	400 mm/min	250 mm/min	alternative	
< 3 mm	6 mm	40 mm	80 mm	50 mm	6 mm	1	24,000 rpm	1,200 mm/min	350 mm/min		610 3703 02
							16,000 rpm	800 mm/min	300 mm/min	alternative	
							12,000 rpm	600 mm/min	250 mm/min	alternative	
< 3 mm	12 mm	45 mm	83 mm	55 mm	12 mm	1	15,000 rpm	1,500 mm/min	350 mm/min		610 3703 05
							12,000 rpm	1,200 mm/min	250 mm/min	alternative	



## 5.1 | TOOLS FOR MACHINING PVC DOORS WITH STEEL REINFORCEMENT FOR SBZ 122

EluCam and EluCad

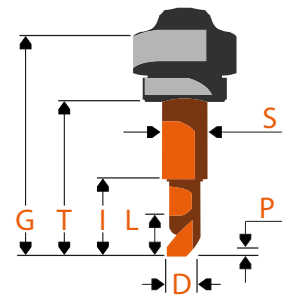
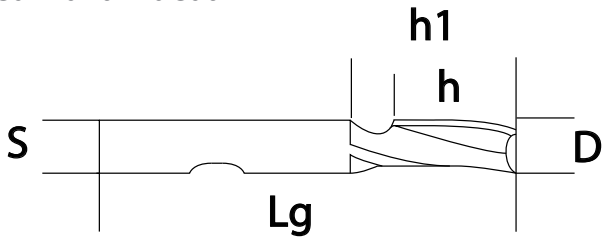

Material	D	h(L)	Lg	h1(l)	T	S	Z				Order no.
FE < 3 mm	8 mm	19 mm	69 mm	22 mm	30 mm	10 mm	4	2,600 rpm	250 mm/min	40 mm/min	060 4030 0800
FE < 3 mm	8 mm	28 mm	78 mm	38 mm	40 mm	10 mm	4	2,600 rpm	250 mm/min	40 mm/min	060 4032 0800
								2,600 = 33 %	250 = 12 %	40 = 10 %	EluCam EluCad
PVC	8 mm	19 mm	69 mm	22 mm	30 mm	10 mm	4	8,000 rpm	2,000 mm/min	400 mm/min	060 4030 0800
PVC	8 mm	28 mm	78 mm	38 mm	40 mm	10 mm	4	8,000 rpm	2,000 mm/min	400 mm/min	060 4032 0800
								8,000 = 100 %	2,000 = 100 %	400 = 100 %	EluCam EluCad

- Ideally, you should mill in counter rotation
- Do not mill rectangles from the centre – start in a corner
- Clamp the profiles with 4 material clamps
- Use the 10 mm supports and clamp the profiles half way up so that the PVC presses the steel
- Machine when dry, with air cooling if available
- Machine PVC and steel separately, otherwise aggressive gases may be produced
- If the cutting quality is insufficient, reduce feed and/or speed
- Use different cutting depths to extend tool life when working with steel

HSS twist drill, DIN 338, type N for steel

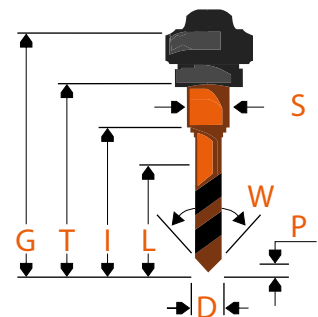
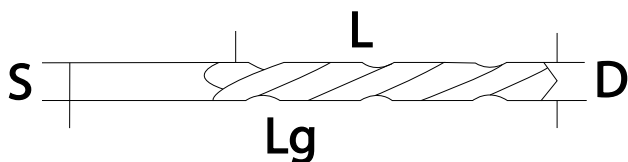



Material	D	L	Lg	S	Z			Order no.
PVC + FE	3 mm	33 mm	57 mm	3 mm	2	2,500 rpm	230 mm/min	060 3000 0300
PVC + FE	5 mm	52 mm	61 mm	5 mm	2	1,600 rpm	190 mm/min	060 3000 0500
PVC + FE	6 mm	57 mm	65 mm	6 mm	2	1,500 rpm	170 mm/min	060 3000 0600

## 5.2 | TOOLS FOR PROCESSING STRUCTURAL PROFILES

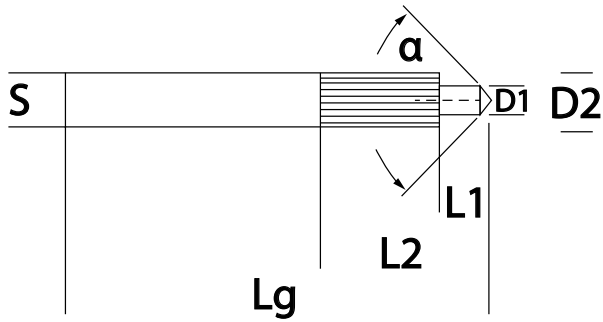
Solid carbide step drill, 180°, with coating



ALU	D1 D2	L1 L2	$\alpha$	Lg	l	s	Z			Order no.
< 4 mm for M6	6.6 mm 11 mm	15 mm 55 mm	140° 180°	102	55 mm	12 mm	2	5,000 rpm	380 mm/min	1891415
< 5 mm for M8	9 mm 15 mm	19 mm 65 mm	140° 180°	115	65 mm	16 mm	2	3,800 rpm	380 mm/min	1891416
< 6 mm for M10	11 mm 18 mm	23 mm 62 mm	140° 180°	123	62 mm	18 mm	2	3,000 rpm	350 mm/min	1891417



Step drilling



Notching

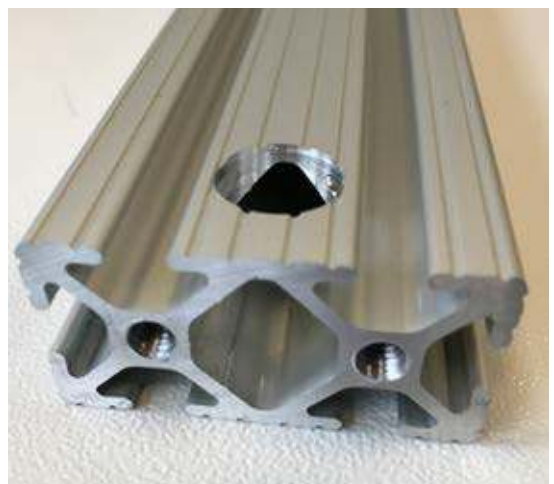

Milling, thread faceside

### 5.3 | TOOLS FOR MACHINING PVC DOORS WITH STEEL REINFORCEMENT FOR SBZ 130

EluCam and EluCad

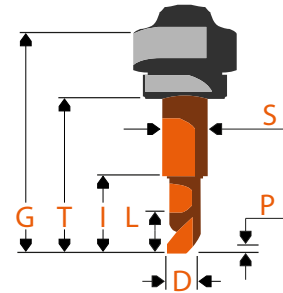
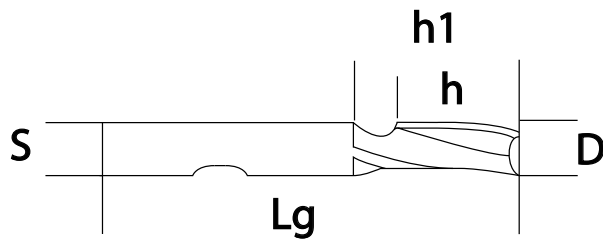

Material	D	h(L)	Lg	h1(l)	T	S	Z					Order no.
FE < 3 mm	8 mm	19 mm	69 mm	22 mm	30 mm	10 mm	4	3,000 rpm	300 mm/min	50 mm/min		060 4030 0800
FE < 3 mm	8 mm	28 mm	78 mm	38 mm	40 mm	10 mm	4	3,000 rpm	300 mm/min	50 mm/min		060 4032 0800
								3,000 = 50 %	300 = 16 %	40 = 10 %	EluCam EluCad	
PVC	8 mm	19 mm	69 mm	22 mm	30 mm	10 mm	4	8,000 rpm	2,000 mm/min	400 mm/min		060 4030 0800
PVC	8 mm	28 mm	78 mm	38 mm	40 mm	10 mm	4	8,000 rpm	2,000 mm/min	400 mm/min		060 4032 0800
								6,000 = 100 %	1,800 = 100 %	400 = 100 %	EluCam EluCad	

- Ideally, you should mill in counter rotation
- Do not mill rectangles from the centre – start in a corner
- Clamp the profiles with 4 material clamps
- Use the 10 mm supports and clamp the profiles half way up so that the PVC presses the steel
- Machine when dry, with air cooling for SBZ 130s built from 08/2004
- Machine PVC and steel separately, otherwise aggressive gases may be produced
- If the cutting quality is insufficient, reduce feed and/or speed
- Use different cutting depths to extend tool life when working with steel

### HSS twist drill, DIN 338, type N for steel

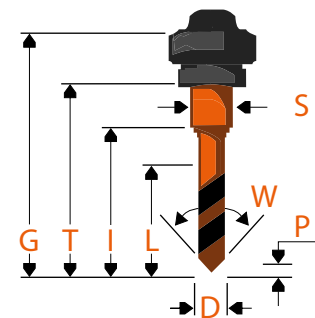
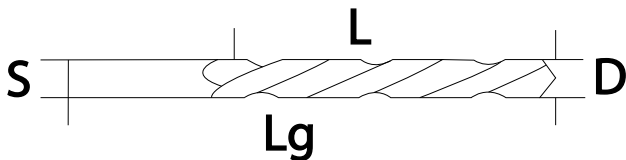

Material	D	L	Lg	S	Z			Order no.
PVC + FE	3 mm	33 mm	57 mm	3 mm	2	2,500 rpm	230 mm/min	060 3000 0300
PVC + FE	5 mm	52 mm	61 mm	5 mm	2	1,600 rpm	190 mm/min	060 3000 0500
PVC + FE	6 mm	57 mm	65 mm	6 mm	2	1,500 rpm	170 mm/min	060 3000 0600

## 5.4 | TOOLS FOR MACHINING STAINLESS STEEL ROUND TUBES/RAILINGS

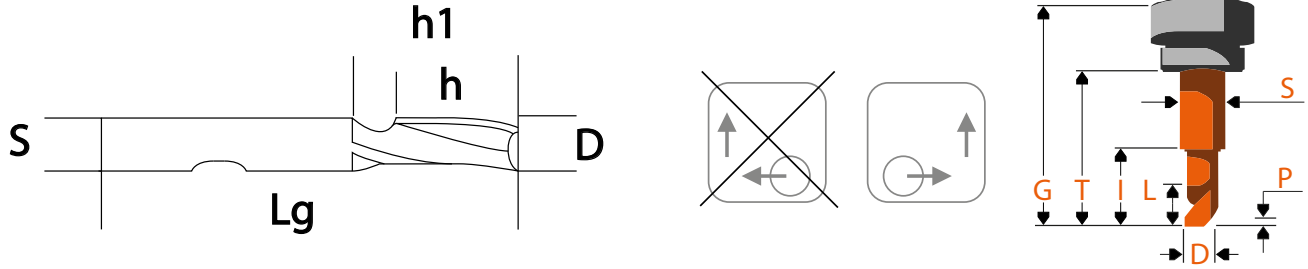

Step	INOX	D	h(L)	Lg	h1	T	S	Z				Order no.
1	< 2 mm	8 mm	28 mm	78 mm	38 mm	45 mm	10 mm	4	500 rpm	100 mm/min		PM 060 4032 0800
2	< 2 mm	8 mm	28 mm	78 mm	38 mm	45 mm	10 mm	4	750 rpm		30 mm/min	PM 060 4032 0800

Tested INOX materials: 304, 316, 316L, V2A, 1.4301 on SBZ 130 with water cooling

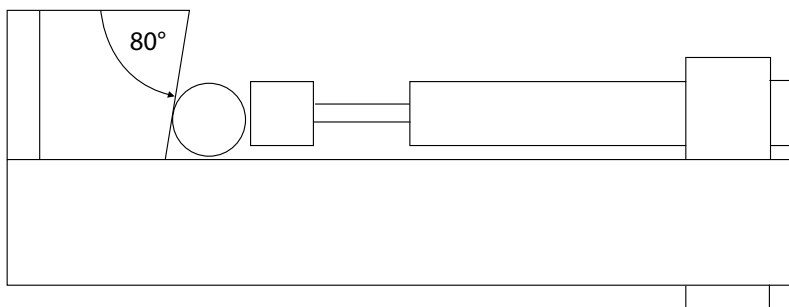
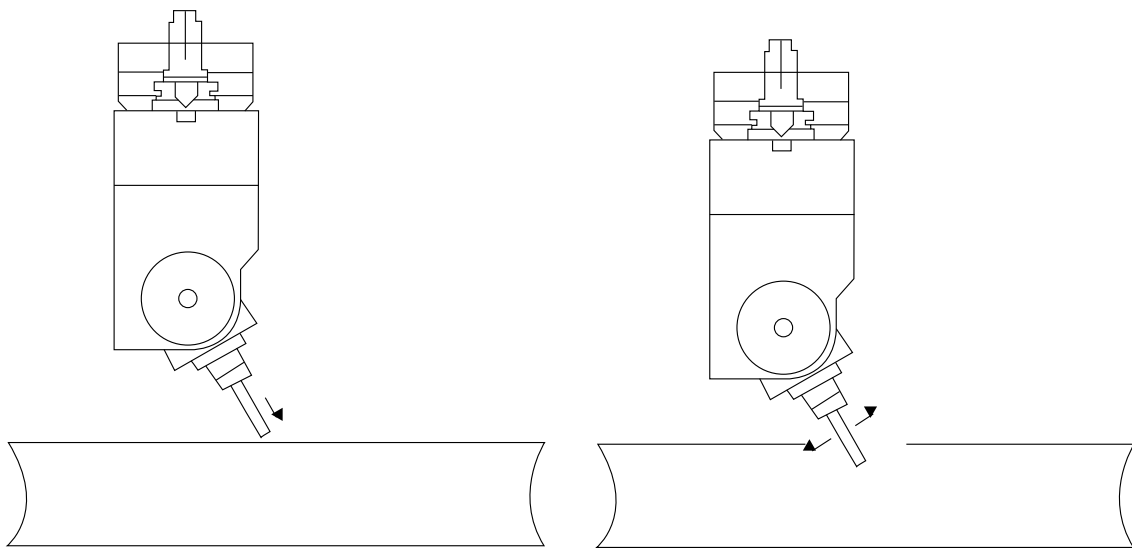

## 5.5 | TOOLS FOR MACHINING FURNITURE PROFILES

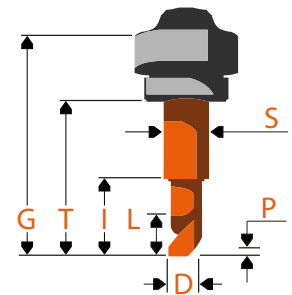
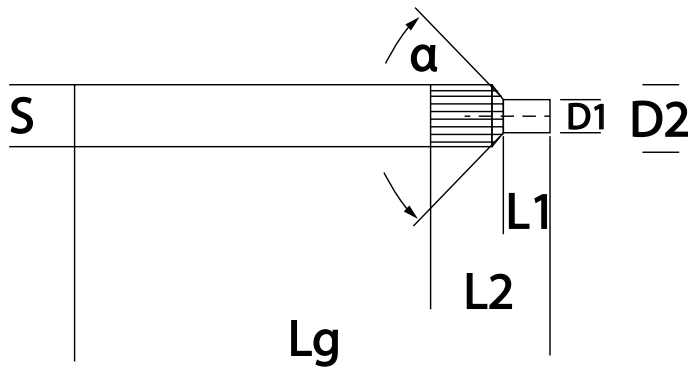
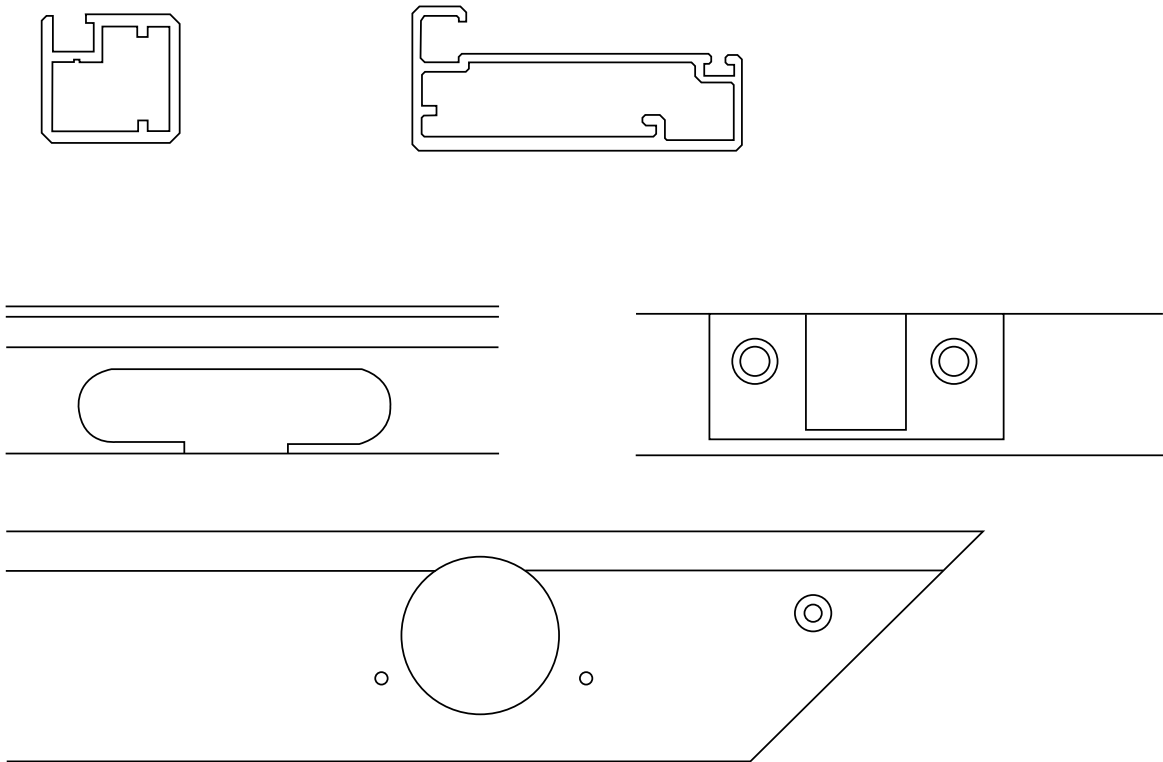

ALU	D1 D2	L1 L2	$\alpha$	Lg	l	S	Z			Order no.
< 2 mm	4.5 mm 8 mm	6 mm 20 mm	90°	70 mm	6 mm 20 mm	8 mm	2	12,000 rpm	300 mm/min	060 4099 0613
< 2 mm	4.2 mm 8 mm	6 mm 20 mm	120°	80 mm	6 mm 20 mm	8 mm	2	12,000 rpm	300 mm/min	060 4099 0181

ALU	D	L	Lg	T	S	Z					Order no.
< 2 mm	10 mm	22 mm	72 mm	40 mm	10 mm	2	12,000 rpm	800 mm/min	300 mm/min	HSS	150 3660 10
							6,000 rpm		200 mm/min	alternative	
< 3 mm	10 mm	22 mm	70 mm	40 mm	10 mm	2	24,000 rpm	3,000 mm/min	400 mm/min	HM	140 3902 10

## 5.6 | MACHINING POST PROFILES IN METAL CONSTRUCTION

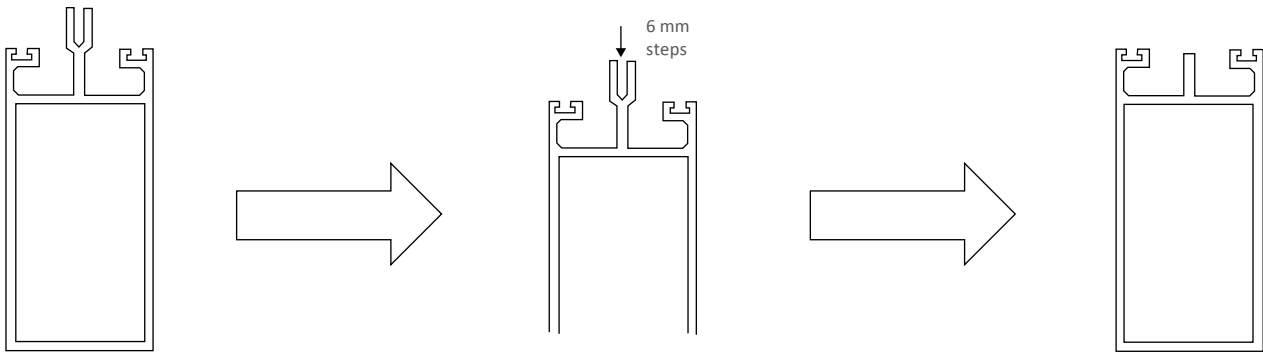

### HM milling cutter

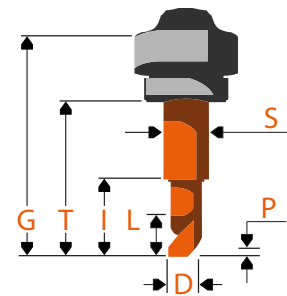
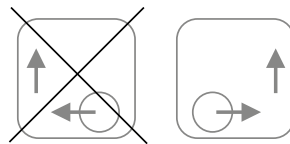
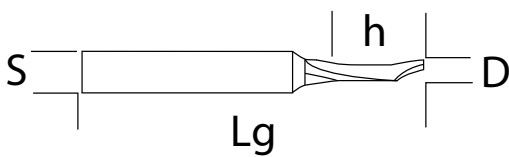

ALU Step	D	h(L)	Lg	T	S	Z				Order no.
6 mm	12 mm	22 mm	70 mm	40 mm	12 mm	2	18,000 rpm	1,800 mm/min	350 mm/min	140 3902 12
							12,000 rpm	1,200 mm/min	250 mm/min	alternative
							6,000 rpm	800 mm/min	200 mm/min	alternative
8 mm	16 mm	32 mm	102 mm	70 mm	16 mm	3	18,000 rpm	1,800 mm/min	300 mm/min	140 3913 16

### Disc milling cutter for aluminium

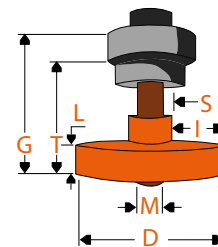
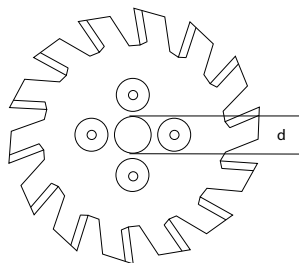

ALU Step	D	L	l	d	Z			Order no.
6 mm	92 mm	6 mm	25 mm	16 mm	14	6,000 rpm	1,000 mm/min	150 3795 00
						6,000 rpm	1,500 mm/min	alternative
						6,000 rpm	2,000 mm/min	alternative

## 5.7 | MACHINING SANDWICH PANELS FOR SECTIONAL DOORS



PM (powder steel) milling cutter with coating

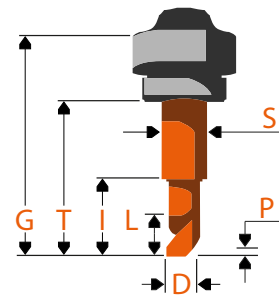
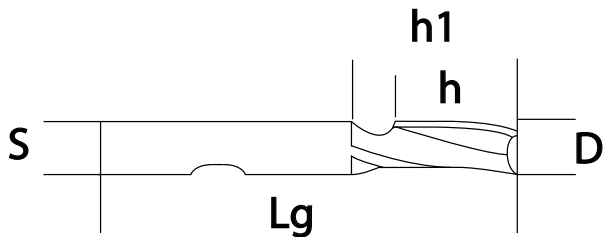

FE and foam	D	h(L)	Lg	h1(l)	T	S	Z				Order no.
FE < 1 mm	12 mm	53 mm	110 mm	65 mm	25 mm	12 mm	4	2,500 rpm	1,200 mm/min	150 mm/min	PM 060 4031 1200

HSS twist drill, DIN 338, type N for steel

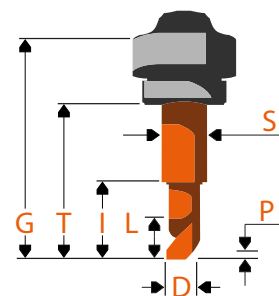
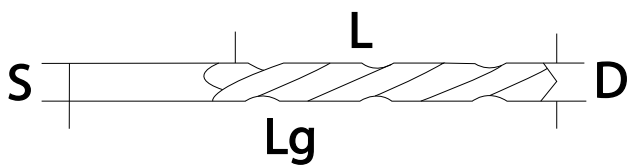

FE and foam	D	Lg	S	Z			Order no.
FE < 1 mm	4.2 mm	75 mm	4.2 mm	2	2,830 rpm	500 mm/min	060 3000 0420

## 6.1 | ER 32, ER 25, ER 20, ER 16 COLLETS

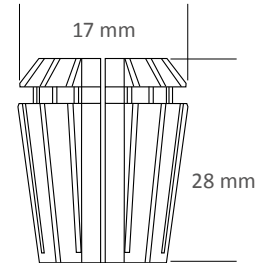
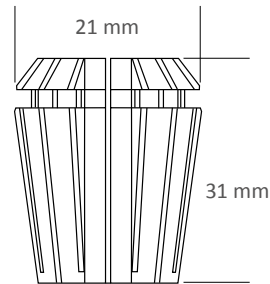
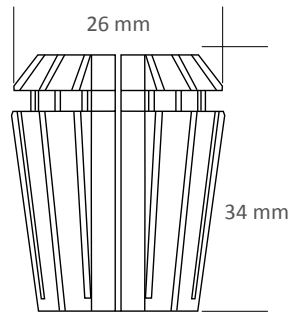
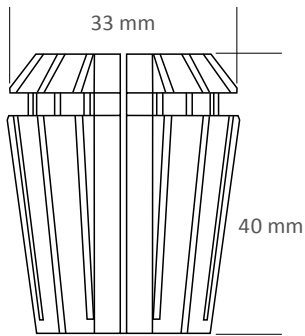

ER 32	
Clamping range	Order no.
2-3 mm	130 3510 08
3-4 mm	130 3510 06
4-5 mm	130 3510 05
5-6 mm	130 3510 07
6-7 mm	130 3510 09
<b>7-8 mm</b>	<b>130 3510 00</b>
8-9 mm	130 3510 26
<b>9-10 mm</b>	<b>130 3510 01</b>
10-11 mm	130 3510 27
<b>11-12 mm</b>	<b>130 3510 02</b>
12-13 mm	130 3510 28
13-14 mm	130 3510 29
14-15 mm	130 3510 30
<b>15-16 mm</b>	<b>130 3510 03</b>
16-17 mm	130 3510 31
17-18 mm	130 3510 32
18-19 mm	130 3510 33
<b>19-20 mm</b>	<b>130 3510 04</b>
<b>Collet set for ER 32 (3-20 mm)</b>	<b>151 2022 01</b>

ER 25	
Clamping range	Order no.
3-4 mm	130 3510 59
4-5 mm	130 3510 54
5-6 mm	130 3510 57
<b>7-8 mm</b>	<b>130 3510 58</b>
8-9 mm	130 3510 53
<b>9-10 mm</b>	<b>130 3510 51</b>
10-11 mm	130 3510 55
<b>11-12 mm</b>	<b>130 3510 64</b>
12-13 mm	130 3510 56
<b>15-16 mm</b>	<b>130 3510 50</b>

ER 20	
Clamping range	Order no.
2-3 mm	151 3510 02
3-4 mm	151 3510 03
4-5 mm	151 3510 04
5-6 mm	151 3510 05
6-7 mm	151 3510 06
<b>7-8 mm</b>	<b>151 3510 07</b>
8-9 mm	151 3510 08
<b>9-10 mm</b>	<b>151 3510 09</b>
<b>10-11 mm</b>	<b>151 3510 00</b>
11-12 mm	151 3510 10
<b>12-13 mm</b>	<b>151 3510 01</b>
<b>ZETA clamping nut for ER 20</b>	<b>140 3521 01</b>

ER 16	
Clamping range	Order no.
0.5-1 mm	122 3510 10
1-1.5 mm	122 3510 15
1.5-2 mm	122 3510 20
2-2.5mm	122 3510 25
2.5-3 mm	122 3510 30
3-4 mm	122 3510 40
4-5 mm	122 3510 50
5-6 mm	122 3510 60
6-7 mm	122 3510 70
<b>7-8 mm</b>	<b>122 3510 80</b>
8-9 mm	122 3510 90
<b>9-10 mm</b>	<b>122 3510 00</b>
<b>Collet set for ER 16 (2-10 mm)</b>	<b>122 3510 02</b>
<b>Clamping nut for ER 16</b>	<b>122 3521 00</b>



## 6.2 | ER COLLETS WITH COMPENSATION SPRING FOR SCREW TAPS

ER 32	
Clamping range	Order no.
4.5 mm	130 3510 35
<b>6 mm</b>	<b>130 3510 36</b>
7 mm	130 3510 37
8 mm	130 3510 38
9 mm	130 3510 39
10 mm	130 3510 40
12 mm	130 3510 68

ER 25	
Clamping range	Order no.
5.5 mm	151 3510 11
<b>6 mm</b>	<b>151 3510 12</b>
7 mm	151 3510 13

ER 16	
Clamping range	Order no.
<b>6 mm</b>	<b>122 3510 61</b>

### Other collets

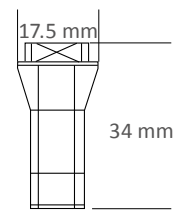
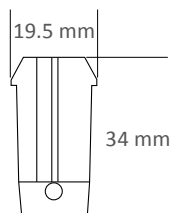

ER 077	
Clamping range	Order no.
3 mm	077 3510 30
3.2 mm	077 3510 32
3.3 mm	077 3510 33
4 mm	077 3510 40
4.2 mm	077 3510 42
5 mm	077 3510 50
5.5 mm	077 3510 55
6 mm	077 3510 60
7 mm	077 3510 70
<b>8 mm</b>	<b>077 3510 80</b>
8.5 mm	077 3510 85
9 mm	077 3510 90
<b>10 mm</b>	<b>077 3511 00</b>
11 mm	077 3511 10
12 mm	077 3511 20
13 mm	077 3510 30
<b>077 clamping nut</b>	<b>112 1224 02</b>

S 8	
Clamping range	Order no.
3 mm	113 3510 01
3.3 mm	113 3510 08
4.1 mm	113 3510 07
4.2 mm	113 3510 06
5 mm	113 3510 10
6 mm	113 3510 11
6.5 mm	113 3510 16
<b>8 mm</b>	<b>113 3510 03</b>
<b>10 mm</b>	<b>113 3510 04</b>

OZ	
Clamping range	Order no.
<b>25 mm collet</b>	<b>150 3510 03</b>

### 6.3 | HSK-F 63 CLAMPING ADAPTERS



L=62



L=97



L=142

Name	077 chuck for collets 3-13 mm		
L	62 mm	97 mm	142 mm
Order no.	136 3508 13	136 3508 18	136 3508 12



ER 32



Quick-action chuck



OZ

Name	ER 32 chuck	Quick-action chuck	OZ, 462 E chuck
Clamping range	see ER 32 collet, p. 40	1-10 mm	see OZ collet, p. 41
Order no.	136 3508 17	136 3508 00	136 3508 22



ER 25

Name	ER 25 chuck with cooling ring
Clamping range	see ER 25 collet, p. 40
Order no.	136 3508 39

## 6.4 | CLAMPING ADAPTERS FOR SBZ 130 AND SBZ 131



ER 32



ER 32



Quick-action chuck

Name	ER 32 collet holder	ER 32 collet holder	Quick-action chuck
L	153 mm	250 mm	165 mm
Clamping range	see collets, p. 40	see collets, p. 40	1-10 mm
Order no.	130 3508 01	130 3508 04	130 3508 05



Name	Quick-action chuck	ER 25 high-speed spindle	ER 32 low-speed spindle
L	135 mm	174 mm	170 mm
i	-	1:3.86	5:1
Clamping range	3-16 mm	see collet chuck, p. 40	see collet chuck, p. 40
Order no.	130 3508 12	131 2056 06	130 2012 01



Name	Holder for disc milling cutters	
d	16 mm	27 mm
Order no.	130 3508 20	130 3508 15

## 6.5 | LUBRICANTS AND COOLANTS



### Standard lubricant

Name		Order no.
Supra NEOC high-performance cutting fluid	0.5 l	088 9070 80
	1 l	088 9070 81
	5 l	088 9070 82
	20 l	088 9070 83
	200 l	088 9070 84

### Coolant and lubricant for increased chip removal

(the alcohol evaporates and cools the tool)

Name		Order no.
Metalon RVB high-performance cutting fluid	0.5 l	088 9070 96
	1 l	088 9070 95
	5 l	088 9070 97
	20 l	088 9070 98
	200 l	088 9070 99

### Coolant for mixing with water

Name		Order no.
Coolant concentrate	0.5 l	088 9070 56
	5 l	088 9070 58
	20 l	088 9070 60

Safety data sheets are available on request by email to [service@elumatec.com](mailto:service@elumatec.com)

## 7.1 | OPTIMISING THE SERVICE LIFE OF TOOLS AND SPINDLES

### Measures to optimise spindle service life:

- Regularly clean the tool holders and the spindle
- Regularly grease the HSK clamp set
- Dispose of damaged clamping devices
- Minimise vibrations by using suitable clamping devices close to where you will be machining
- Minimise vibrations by using the optimum tools and by adjusting speed and feed rates
- Avoid unnecessarily high speeds (see diagram)

### Principle of bearing service life in relation to speed

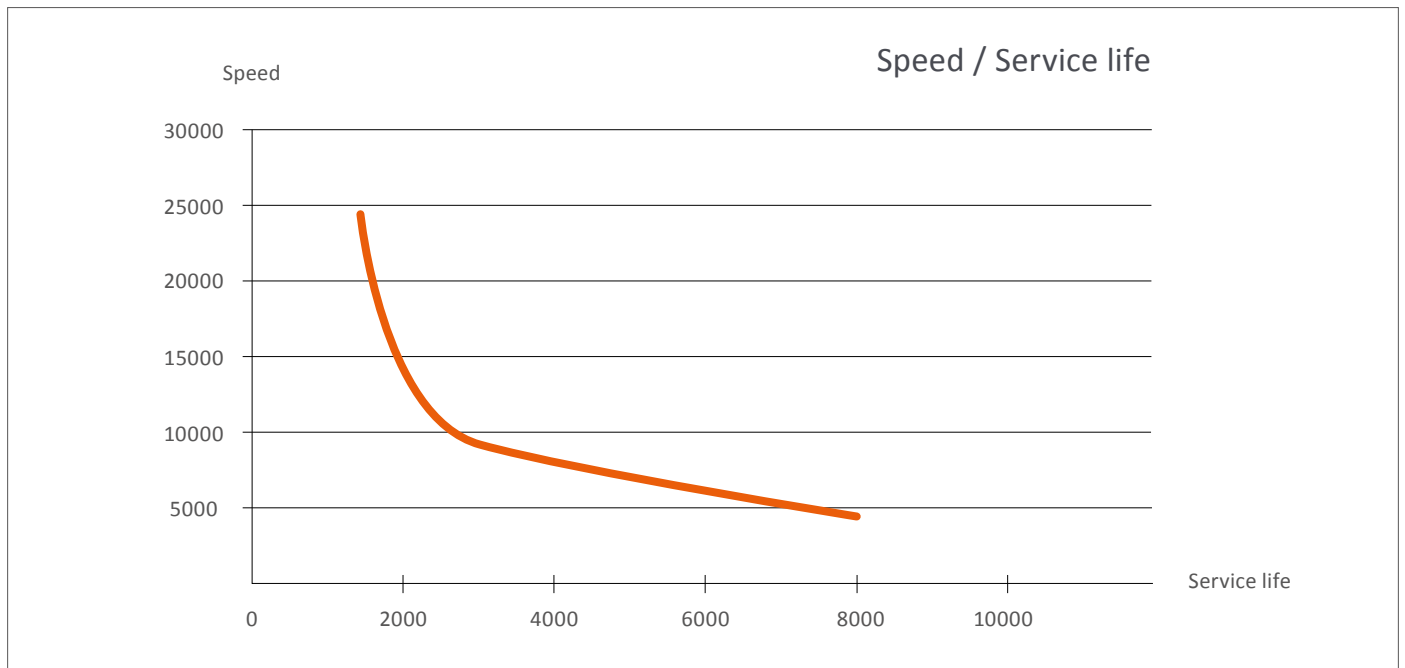

### Cleaning accessories for HSK holder



Name	HSKF-63 inner cone cleaner	HSK-63 outer cone cleaner
Order no.	150 2610 01	151 3540 01

---

---

---

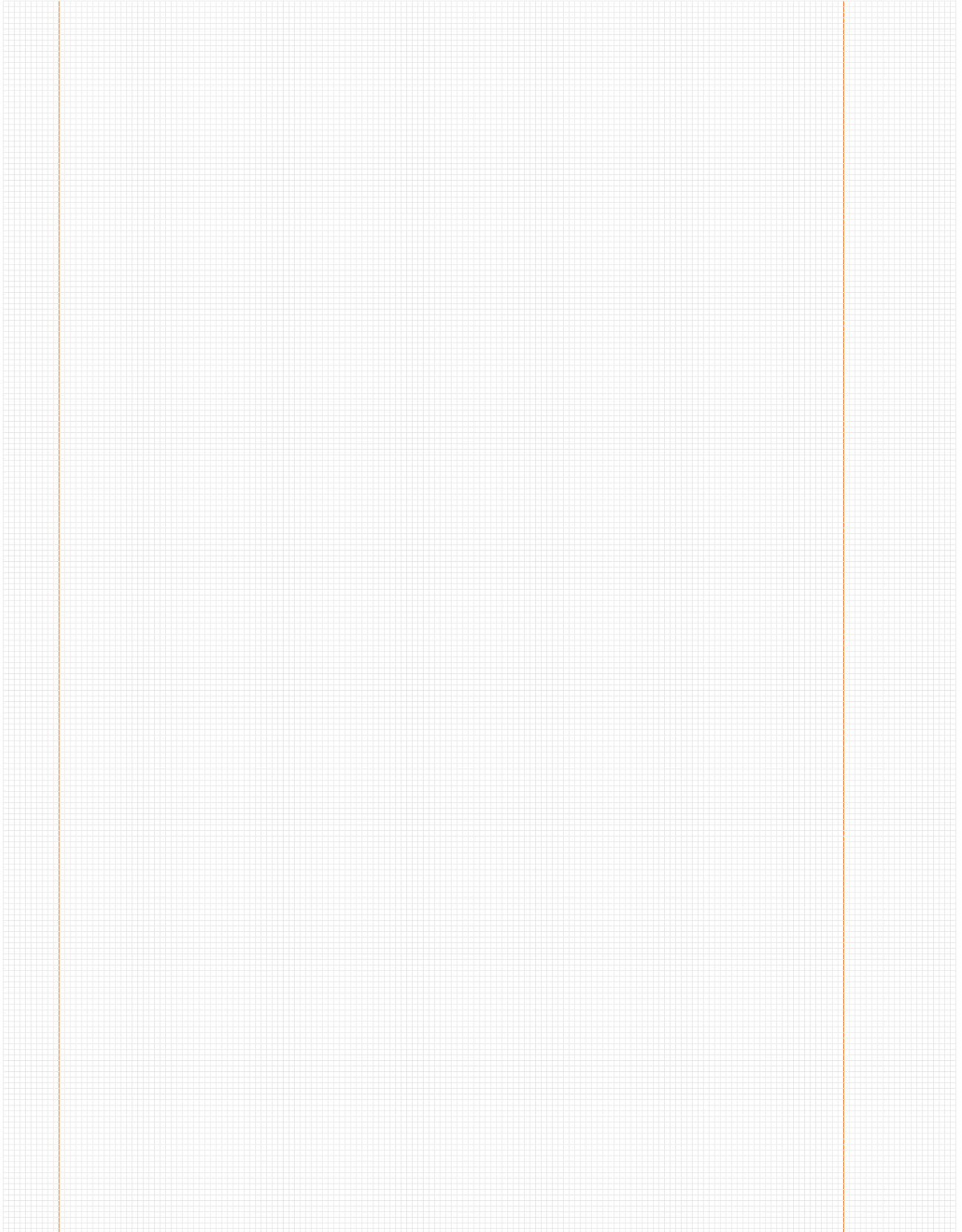



**elumatec AG**

Pinacher Straße 61  
75417 Mühlacker  
Germany

Phone +49 7041 14-0  
Fax +49 7041 14-280  
mail@elumatec.com  
www.elumatec.com

