



Column Flow Drilling Machine
SB P40 ST-FB
SB P40 STG-FB PV electronic

Fig.: SB P40 ST-FB PV electronic

Flow drilling

is being used for the perforation of thin walled metal sheets.

The method of flowdrilling forms a sleeve by reshaping of the existing material. The material prolongation increases the number of leading threads up to three to five times.

The material is not chipped, but used for loadable connections.

Advantages of flow drilling:

- ▶ Low costs per thread
- ▶ Loadable joints
- ▶ High-quality threads
- ▶ No special equipment needed
- ▶ Low start-up costs
- ▶ No third party material needed
- ▶ Less steps of production
- ▶ No chip removal

Accessories

- ▶ Combined drilling table/
machine vice opening 120 mm,
clamping width 210 mm
Order No. 281.210

Available software options for PV electronic

- ▶ **Safety module** – Spindle stops automatically in upper position
Order No. 290.613
- ▶ **Chip cutter module**
to avoid long chips
Order No. 290.612
- ▶ **Multi feed unit** – Four free selectable feed speeds per cycle
Order No. 290.614

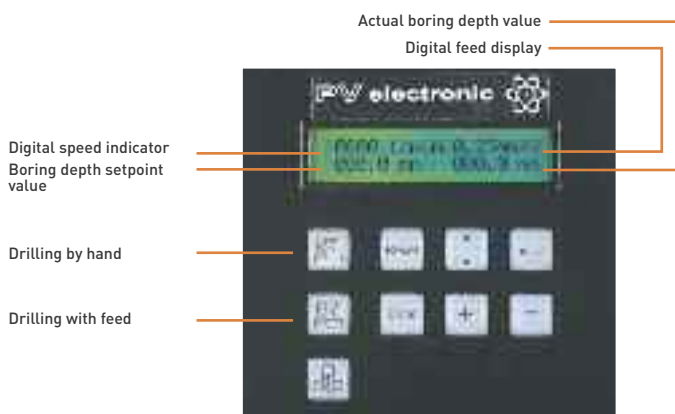

Technical Data

Flow Drilling capacity (3 mm sheet iron)	20 mm
Spindle	MKIV
Drilling depth	160 mm
Distance column-spindle	300 mm
Machine-column diameter	Ø 125 mm
Usable work table surface (L x W)	590 x 450 mm
T-slot size	quantity 2, distance 160 mm size width 14/26 mm
Speed indication	digital
Drill depth indication	digital
Drilling depth stop	With fine adjustment
Feed	manual
Table height adjustment	With rack
Machine size (WxDxH)	590 x 830 x 2,100 mm
Machine size (incl. packaging) (WxDxH)	670 x 1,100 x 2,140 mm
Motor 400 V 50 Hz, single speed motor	3 kW
Spindle speed, inf. var with speed range R1	500-4,000 1/min
Motor 400 V 50 Hz	1.5/3 kW 2-speed motor
Spindle speed, inf. var with speed range R2	250-4,000 1/min

SB P40 ST-FB

Distance spindle table	150-700 mm
Weight	420 kg
Order No. R1	205.212
Order No. R2	205.213

SPECIAL OPTIONS ON PAGE 64 | 1 | 2 | 3 | 4 | 5 | 6 | 11

SB P40 STG-FB PV electronic

Feed inf. var. with electromagnetic clutch and digital display	0-300 mm/min
Distance spindle table	150-700 mm
Weight	445 kg
Order No. R1	205.217
Order No. R2	205.218

SPECIAL OPTIONS ON PAGE 64 | 1 | 2 | 3 | 4 | 5 | 7 | 11

FURTHER TAPPING AND DRILLING TOOLS STARTING P. 70

